

This compact machine includes cabinet, single media system, dust collector, reclaim, four-axis gantry robot nozzle manipulator and one axis turntable.

Blast Cabinet Enclosure 5' 6" H x 4' D x 6' W (other sizes available). ¼" – ½" A36 steel welded construction. Powder coated finish.

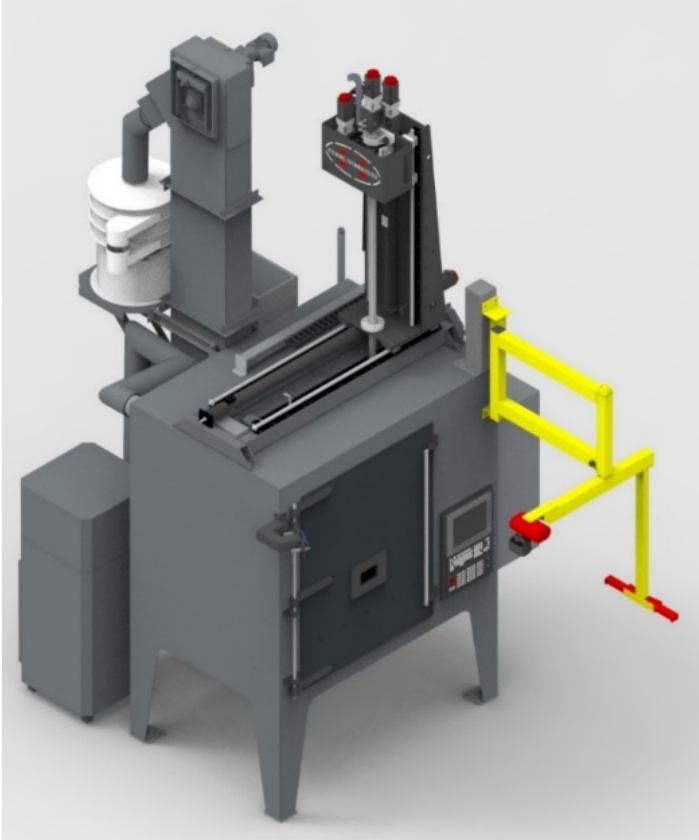

Gantry Robot Nozzle Manipulator - The closed loop-controlled nozzle manipulator is designed to provide programmable coordinated motion in the horizontal (X-Axis), vertical (Z-Axis), rotary wrist (B-Axis), and miter (A-Axis) directions.

Rotary Turntable - C-Axis is a horizontally mounted table with a 24-inch outside diameter and 250 lb. on center capacity. Programmable C-Axis operated in both indexing mode and spindle rotary mode (depending upon control selected).

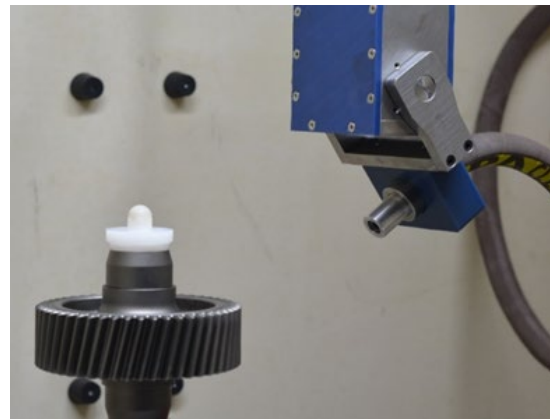

Pressure Blast Generator - The shot peen media is fed into the compressed air stream from a six cubic foot capacity pressure vessel. Includes an Electronics, Inc., MagnaValve™ for shot peen media flow, a Proportion-Air air volume booster with electronic air pressure regulator for air pressure, and media level sensor.

Media Cleaning and Classification System - A bucket elevator conveys the shot peen media to a classifier that screens the peening media before reuse.

Dust Collector System – Compact cartridge style dust collector designed to meet customer needs. Can be located outdoors.

Energy efficiency - our elevator and dust collector combination utilize 3.0 total horsepower compared to competitors vacuum recovery systems that typically require a 5-7.5 HP motor for a comparable system.





Control System Options include FANUC Oi-f, Rockwell Automation PNC, Delta Tau Power Brick (Winter 2022) with each control offering:

- Standard M and G code programming.
- Visual Shot Peening™ - Our graphical interface (HMI) that displays key process variables including motion, air pressure, shot flow, program status, and alarm status.
- Teach Pendant – is included to facilitate programming.
- Process Monitoring - Alarms include machine status such as 'door open' or 'reclaim not on', HI/LOW shot flow, HI/LOW air pressure, X, Y, A, B, and C axis drive faults including speed, following error and over-travel.
- Optional Data Logging - Machine events are logged to an SQL database for analysis.



Additional Options Include:

- Cabinet mounted jib crane with 250 lb. capacity.
- Dual media capability adds a second pressure blast generator and enhanced screening.
- Three (3) nozzle gun assembly for fast coverage of larger parts. Includes larger pressure blast generator.
- Rotary ID peening attachment for small hole peening.