



# PAINT BOOTH BASICS 101



# CONTENTS

PAINT BOOTH BASICS 101.....	3
What is a Paint Booth?	
BASIC COMPONENTS OF A BOOTH .....	4-6
Working Chamber	
Exhaust Chamber	
Exhaust Filtration	
UNDERSTANDING THE CODES.....	7-13
Building Codes	
Construction Standards	
NFPA 33	
Electrical Standards	
Fire Ratings	
Authority Having Jurisdiction (AHJ)	
Approval Process & Listing Requirements	
AIRFLOW REQUIREMENTS .....	14-15
CFM Requirements for Enclosed Booths	
Open Face/Conveyor Opening Air Velocity	
NON-PRESSURIZED VS. PRESSURIZED .....	16-20
Non-Pressurized Booths	
Non-Pressurized Crossdraft Booths	
Pressurized Crossdraft Booths	
Pressurized Downdraft Booths	
AIRFLOW DESIGNS .....	21-24
Downdraft Booths	
Side Downdraft Booths	
Semi-Downdraft Booths	
Crossdraft Booths	
SELECTING A BOOTH.....	25-29
Which Booth Do I Choose?	
What to Consider When Designing a Booth	
Equipment Installation Questions	
Determining Booth Size	
Exit Doors	

<b>OTHER COMPONENTS.....</b>	<b>30-33</b>
Exhaust Fans	
Exhaust Ducting	
Exhaust Pit	
Manometer	
Intake Plenum & Intake Filter	
Lighting	
Air Solenoid Valve	
<b>AIR MAKE-UP UNITS (AMUs).....</b>	<b>34-40</b>
Benefits of an AMU	
AMU Arrangements	
AMU Types	
Variable Air Volume (VAV) Curing	
Recirculation	
Two Types of Heating Systems	
Heating Efficiency	
<b>GFS INDUSTRIAL PAINT BOOTHS.....</b>	<b>41-44</b>
Dry Filter: Open Face & Bench Booths	
Dry Filter: Enclosed Finishing Booths	
General Purpose Booths	
Large Equipment Booths	
<b>SALES QUOTING TOOLS.....</b>	<b>45-46</b>
Sales Order Configurator Tool	
Request for Quote (RFQ) Tool	

# PAINT BOOTH BASICS 101

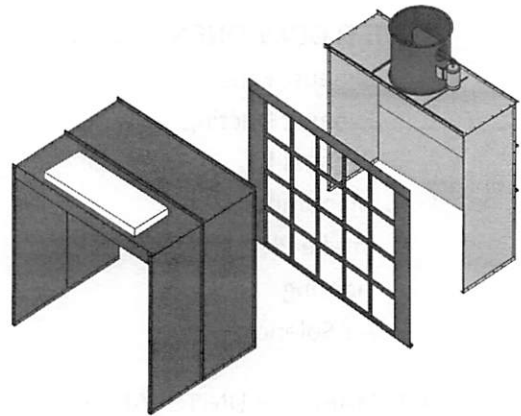

## What is a Paint Booth?

- Required by fire, building and mechanical codes:
  - ETL
  - NFPA
  - OSHA
- Ventilate hazardous vapors such as volatile organic compounds (VOCs)
- Capture and contain overspray
- Protect employees and facility
- Allow for better-quality finishes

---

NOTES:

# BASIC COMPONENTS OF A BOOTH

## Working Chamber

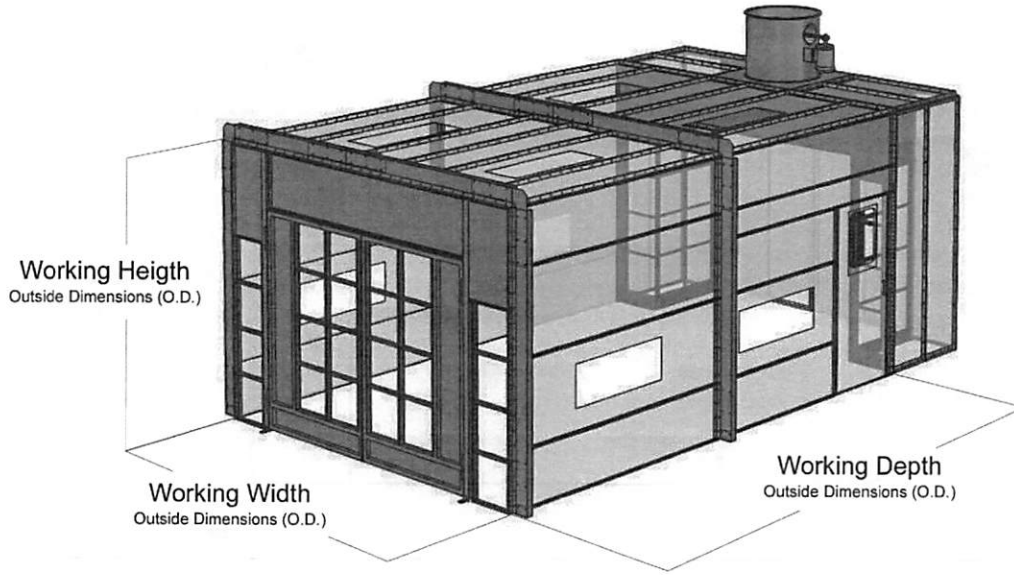

---

NOTES:

model #'s are inside dims -

## Exhaust Chamber

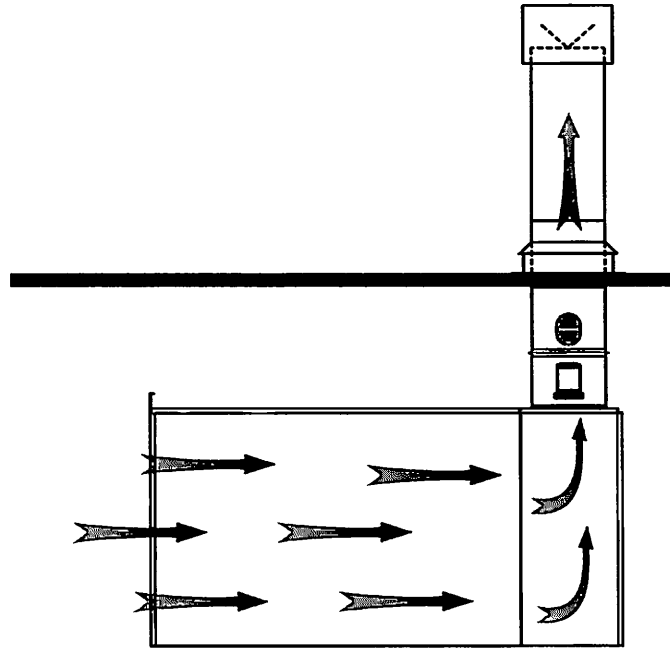

---

NOTES:

## Exhaust Filtration

Filter Pads



Roll Media



Water Filter



- 20x20 filter pads are held in place with wire grid panels
- Roll media filtration offers low maintenance
- All filters are UL listed
- Water filtration is also an option

---

NOTES:

# UNDERSTANDING THE CODES

## Building Codes

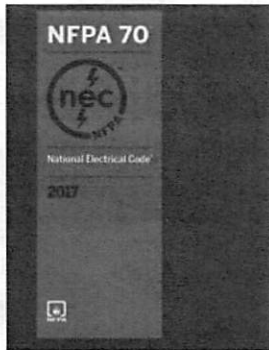

National Electrical Code



International Fire Code



International Building Code



International Mechanical Code

---

### NOTES:

\* NFPA 33

\* UL/ETL

\* GFS does not do permitting

\* ASK customer if there are any special codes to be met (RFQ)



## Construction Standards

National Fire Protection Association (NFPA)

- NFPA 33
- NFPA 34 *Mix Rooms*
- NFPA 86 *Ovens*
- NFPA 91



---

NOTES:

## NFPA 33

- Spray Area (3.3.2.3)
- Spray Room (3.3.15)
- Spray Booth (3.3.14)

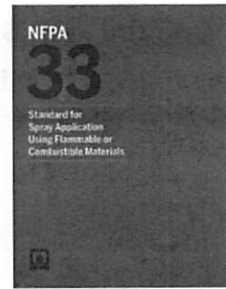

---

NOTES:

## Electrical Standards

Class I, Division 2 area extends 3 feet from the opening of the paint booth

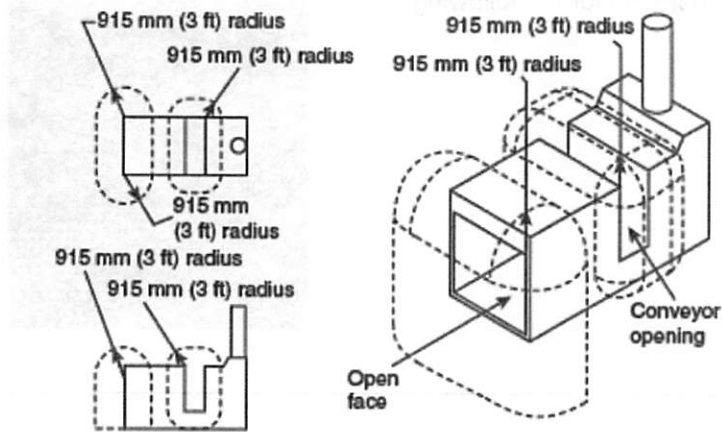

**FIGURE 6.5.2 Class I, Division 2; Class I, Zone 2; Class II, Division 2; or Zone 22 Locations Adjacent to an Open-Face or Open-Front Spray Booth or Spray Room.**

NOTES:

## Fire Ratings

Pre-engineered paint booths constructed of at least 18-gauge galvanized steel to meet IFC and NFPA 33 requirements don't have a fire rating.

The IFC and NFPA require fire separation for the following occupancies:

- Assembly
- Educational
- Institutional
- Residential

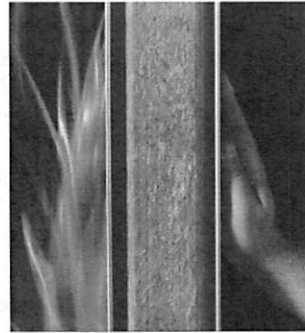

---

NOTES:

## Authority Having Jurisdiction (AHJ)

- Building official
- Commanding officer
- Department official
- Electrical inspector
- Fire marshal
- Health department



---

NOTES:

## Approval Process & Listing Requirements

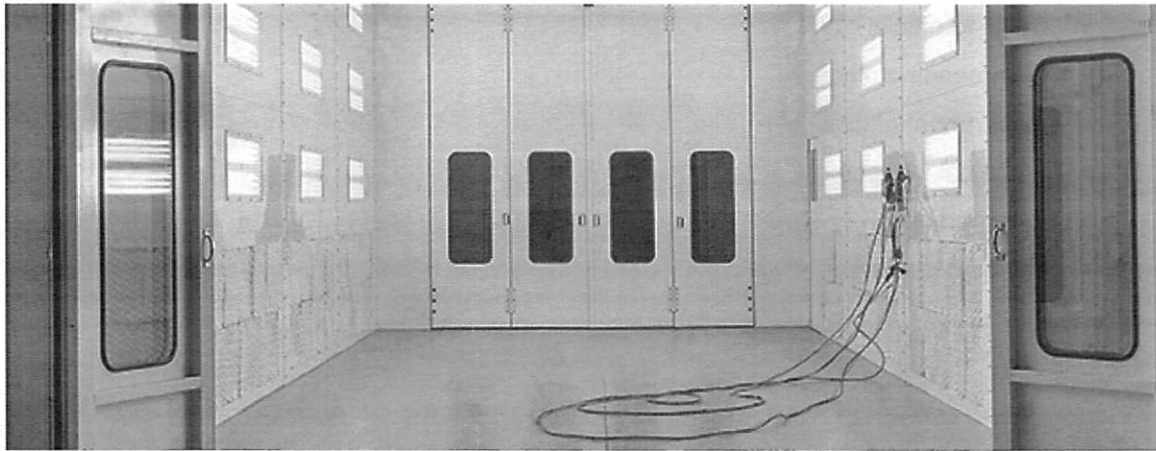

Paint booths are NOT required to be UL or ETL listed

- Before issuing approval, the AHJ may require evidence of compliance
- To minimize costs, identify requests for field listings or third-party approvals before equipment is purchased

---

NOTES:

# AIRFLOW REQUIREMENTS

## CFM Requirements for Enclosed Booths

Open Face & Enclosed Finishing

- Minimum 100 FPM

Large Equipment & General Purpose

- Crossdraft: 75-100 FPM *W x H x 100 FPM*
- **Downdraft: 35-50 FPM\*** *W x D x 35-50 FPM*
- Electrostatic/automatic: Minimum 50 FPM

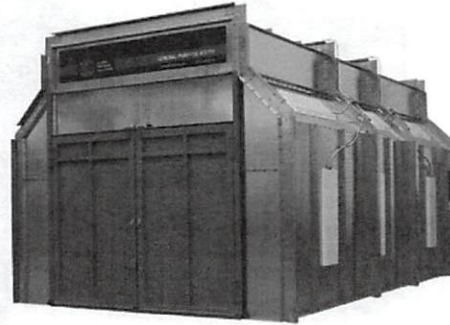
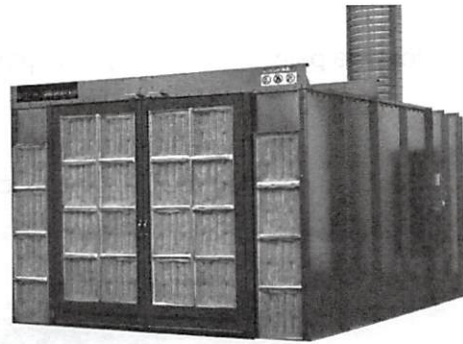

**\*Determined by application and part size**

NOTES:

*over sp.*  
25% of the LE Limit



## Open Face Booth/Conveyor Opening Air Velocity

Into the paint booth through all openings:

- No less than 100 FPM

For fixed or automated electrostatic spray application:

- No less than 50 FPM *(no human spraying)*

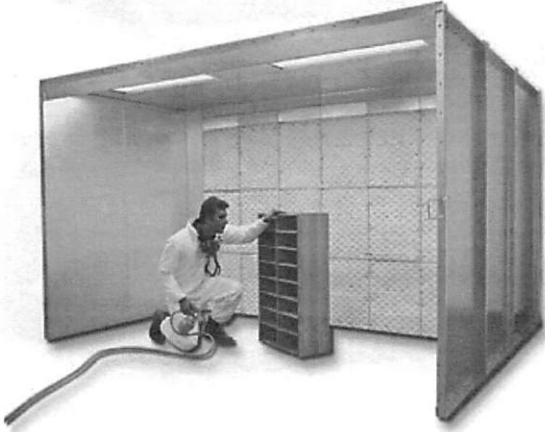

---

NOTES:



# NON-PRESSURIZED VS. PRESSURIZED

## Non-Pressurized Booths

Open Face Booth

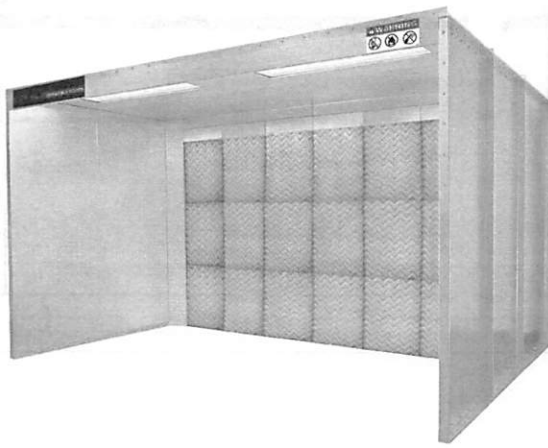

Filtered Swing Door with High-Efficiency Filtration

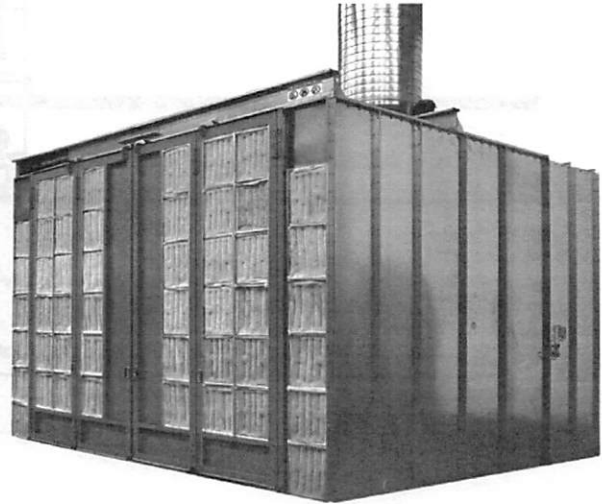

---

NOTES:

## Non-Pressurized Crossdraft Booths

- Less expensive than pressurized booths
- Use less shop floor space
- High-efficiency intake filters remove dust and dirt prior to entering the booth

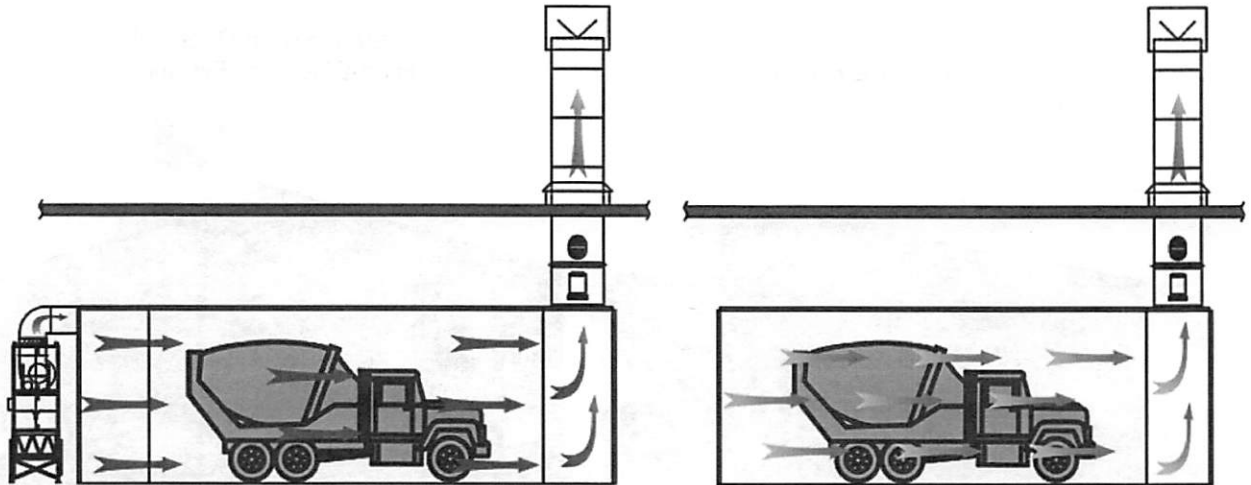

NOTES:

## Pressurized Crossdraft Booths

Chamber size designed for optimal airflow and to maximize filter life

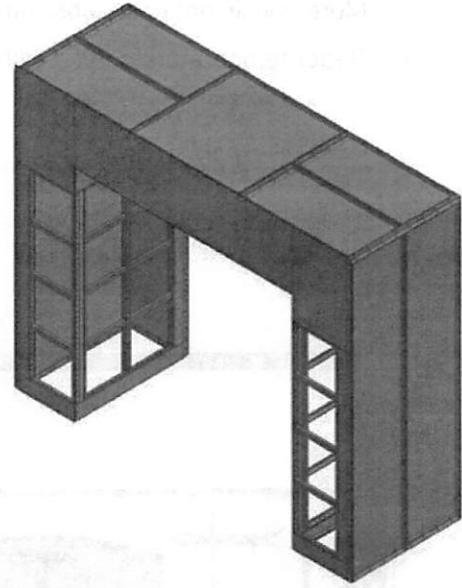

---

NOTES:

air make up unit  
or  
intake fan

## Pressurized Crossdraft Booths

- Cleaner environment
- More consistent paint jobs with booth balancing
- Better temperature control with heated Air Make-Up Unit (AMU)

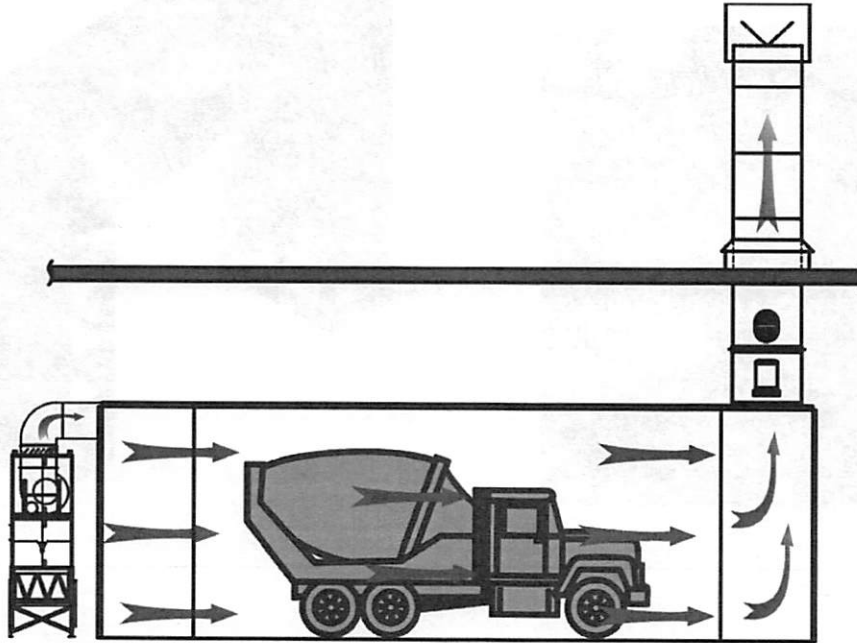

NOTES:

## Pressurized Downdraft Booths

Standard Velocity = 35-50 FPM

Side Downdraft

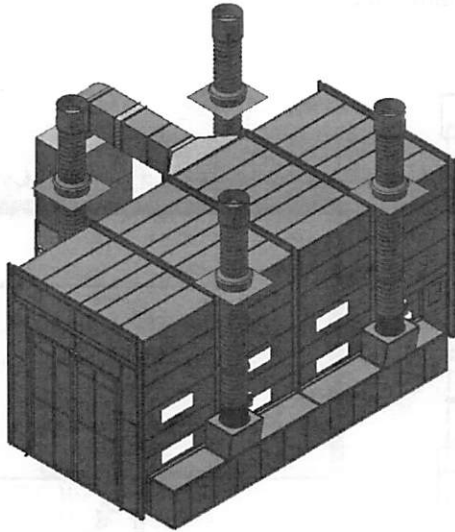

Pit Downdraft

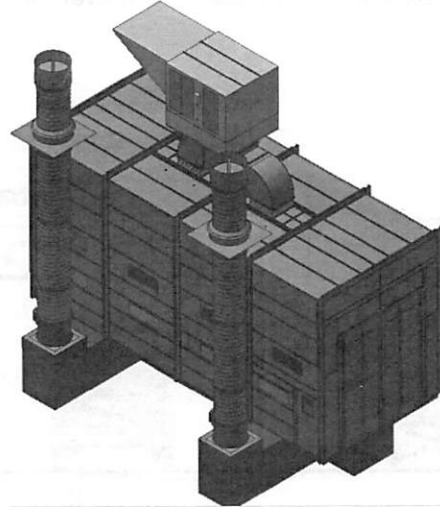

---

NOTES:

↓  
*Can do raised floor  
w/ ramp.*

# AIRFLOW DESIGNS

## Downdraft Booths

Best airflow style for controlling overspray and contamination

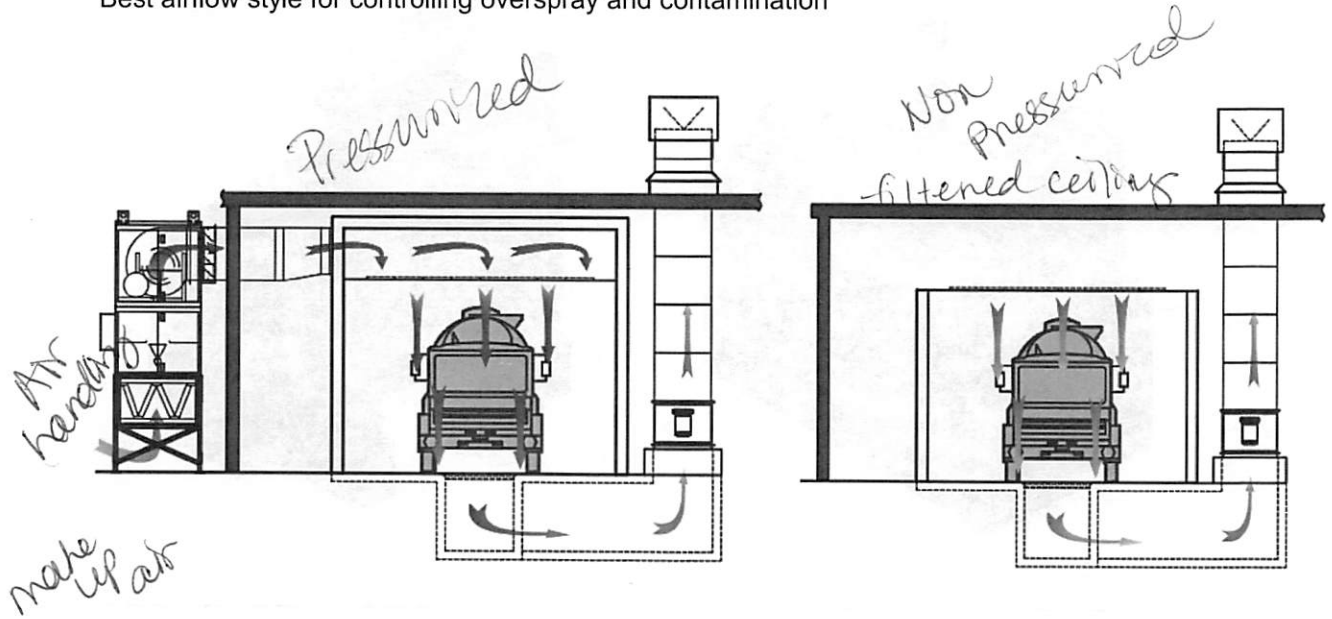

NOTES:

NON-pressurized  
20-40 K CFM  
Replacement air ?

## Side Downdraft Booths

Economical solution for shops without a pit

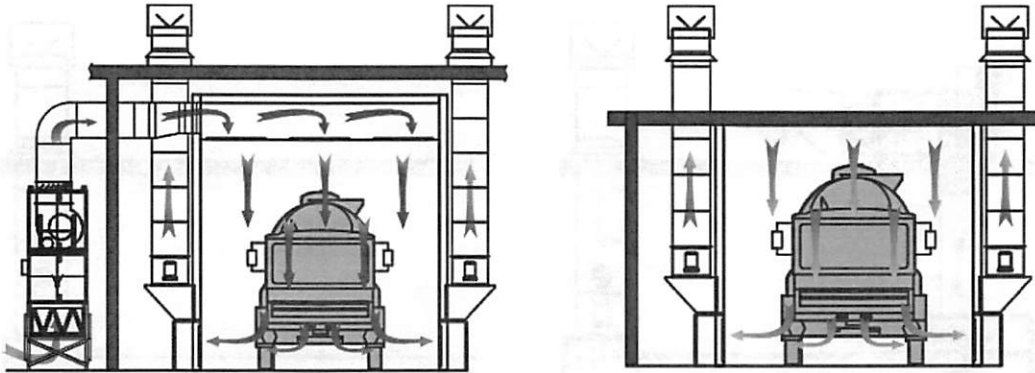

NOTES:

good for multiple painters  
extra cost for extra exhaust

## Semi-Downdraft Booths

Hybrid, combining features of both crossdraft and downdraft booths

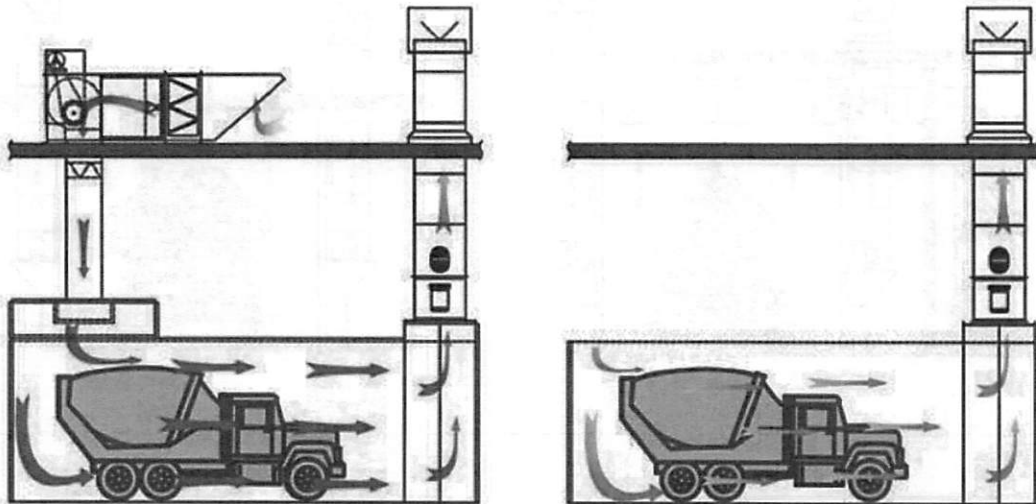

NOTES:

*Auto industry (popular)*



## Crossdraft Booths

Most cost-effective and most popular for industrial applications

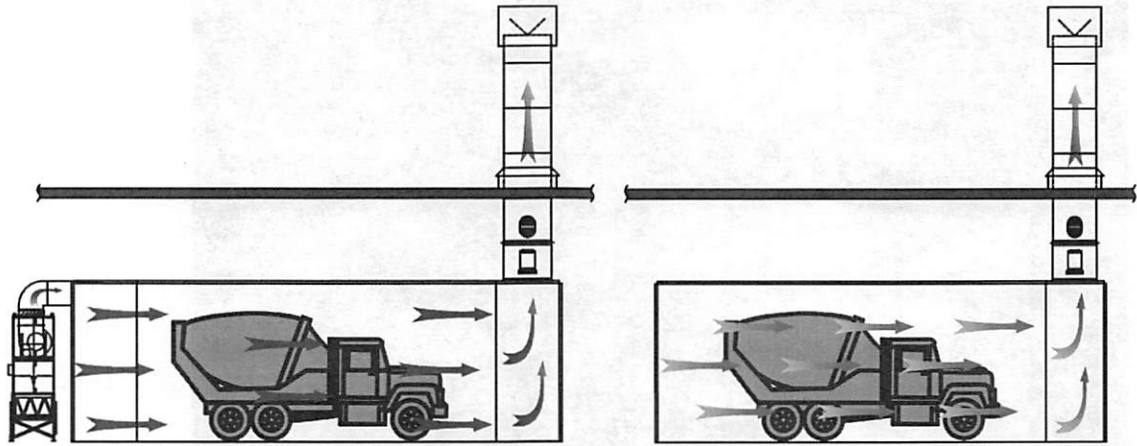

NOTES:

# SELECTING A BOOTH

Which Booth Do I Choose?



---

NOTES:

## What to Consider When Designing a Booth

- Location of the booth within the building
- What the customer is painting
- Coating types and finishing quality
- How the paint is dried
- Hours per day of painting
- Number of painters in the booth
- Utilities available
- \* If the building is rented, leased or owned
- Code/insurance requirements



---

### NOTES:

- Location
- parts
- coating type
- 
-

## Equipment Installation Questions

- Where's the proposed location for the equipment? *look up*
- Are beams, columns or pipes in the way?
- What's the height, pitch and type of the roof?
- Can exhaust ducting go through the roof?
- Are utilities available?
- **What type of fire suppression is needed?**
- Is an Air Make-Up Unit (AMU) part of the project?
- Who's responsible for the permits? *always required* ~~X-GFS~~
- Will local jurisdiction review the permits?
- What's the responsibility of the general contractor and sub-contractors?

*Reg. - but GFS  
does not supply*

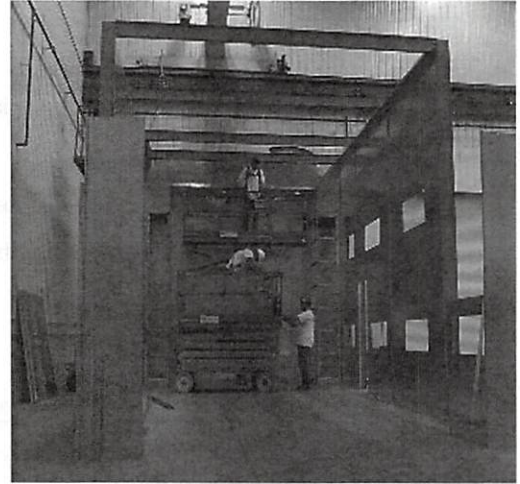

NOTES:

*elbows  
add SP  
will have to  
increase fan/exhaust  
power*

*Need roof height / pitch*

## Determining Booth Size

- Outside dimensions are always larger than inner work area
- Allow:
  - 3 feet on both sides of part
  - 3 feet above part
  - 3 feet between front of part and front of booth

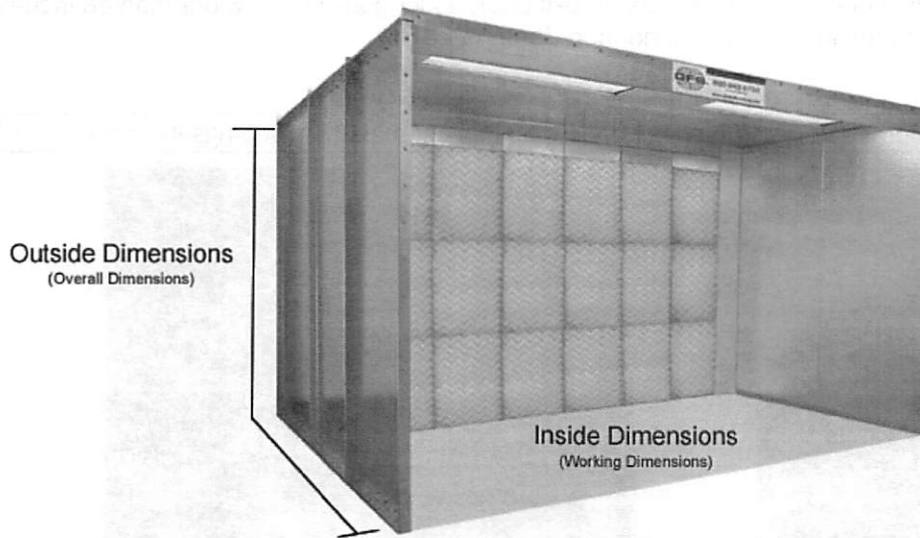

## OPEN FACE BOOTH MODELS

Model No.	Inside Dimensions			Outside Dimensions			Depth
	Width	Height	Depth	Width	Height	Depth	
<b>6 Ft. Wide Booths</b>							
DFOCG-060706-NSB-1L	6'	7'	6'	6' 4"	7' 10"	9' 2"	24
DFOCG-060708-NSB-1L	6'	7'	8'	6' 4"	7' 10"	11' 2"	24
DFOCG-060709-NSB-1L	6'	7'	9'	6' 4"	7' 10"	12' 2"	24
DFOCG-060710-NSB-1L	6'	7'	10'	6' 4"	7' 10"	13' 2"	24
DFOCG-060712-NSB-2L	6'	7'	12'	6' 4"	7' 10"	15' 2"	24

NOTES:

## Exit Doors

- Enclosed paint booths require at least one exit door

NFPA 101: Maximum floor area for a single exit door is 200 square feet; maximum travel distance to an exit door is 50 feet

- The product door can be used as an exit door, as long as it is no wider than 48 inches and has a pressure release of no more than 15 LBF

IBC: Minimum width for a personnel exit door is 30 inches; maximum width is 48 inches



---

NOTES:

# OTHER COMPONENTS

## Exhaust Fans

Tube Axial Fan

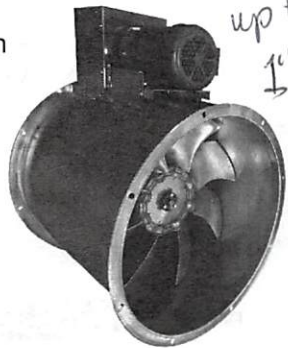

*Common up to 1' SP*

Turbo Fan



*High SP*

NOTES:

## Exhaust Ducting

*make their own*



Spiral duct

Angle ring bolt together

Available in 4-, 6- and 8-foot sections



Spiral duct with cleanout



Plain duct

slip fit

Available in 3-foot sections



Plain duct with cleanout

*cleanout  
↓  
closest pc  
of duct  
to ex. fan  
&  
sprinkler  
head*

NOTES:

*↓  
anything over 15' run*

*not as strong*

## Exhaust Pit

Air is pulled into the filtered exhaust pit in the floor

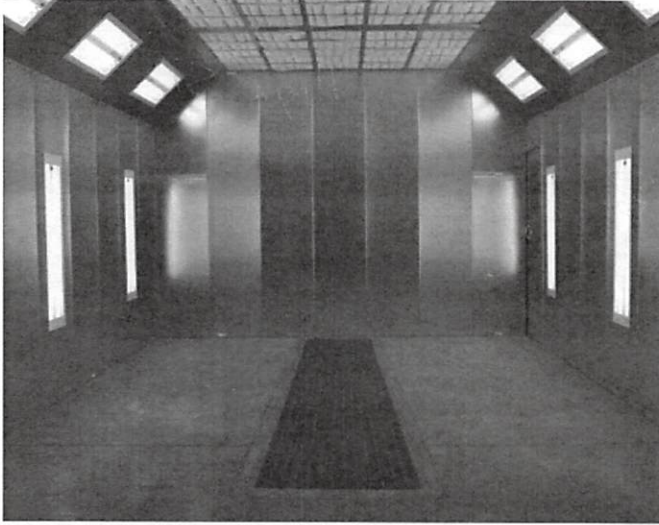

ASK

man load gratings  
or  
H.D. gratings.

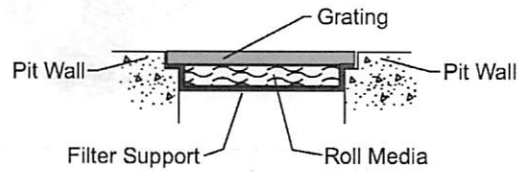

NOTES:

## Manometer

- Included with all booths
- Monitors filter loading

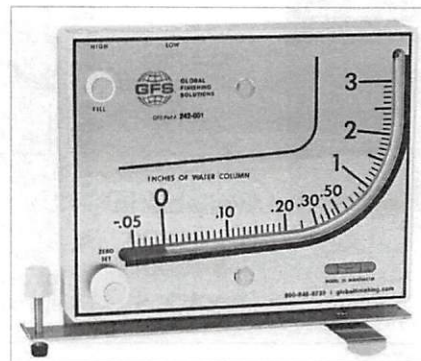

NOTES:



## Intake Plenum & Intake Filter

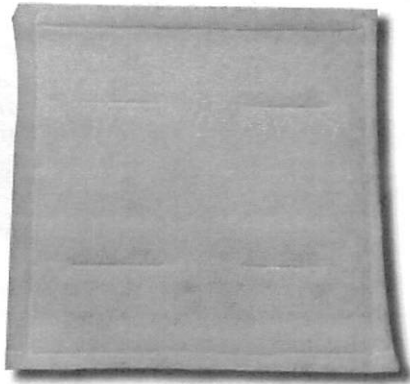

Sticky side goes  
on outside/dirty side.

Tacky Filters: 20" x 20" x 1"

---

NOTES:

## Lighting

- Expertly engineered
- Bulbs: T5, T8 or LED

↓  
tall  
booths

↓  
std.



---

NOTES:

## Air Solenoid Valve

- Prevents spraying in the booth when fans are off or access door is open
- Included with all booths
- 1/2 inch standard or 3/4 inch option

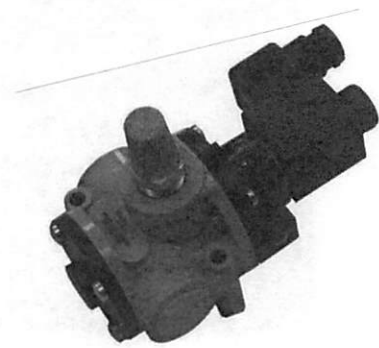

---

NOTES:

# AIR MAKE-UP UNITS (AMUs)

## Benefits of an AMU

- Replaces air exhausted by the paint booth
- Allows for environmental temperature control in paint booth during coating application and curing
- Reduces negative building pressure
- Reduces building HVAC loss

Crossdraft Booth

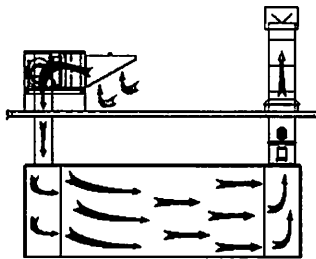

Downdraft Booth

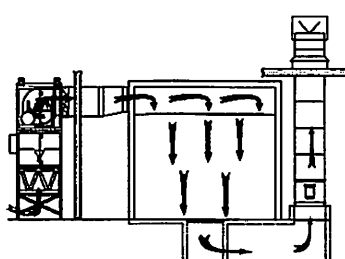

Recirculating Cure Booth (80/20)

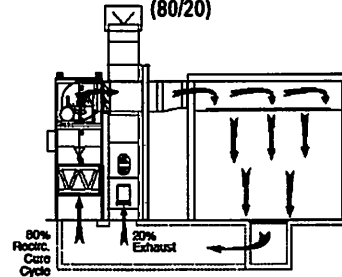

NOTES:

# Pressurized Illustrations

## AMU Arrangements

- Horizontal - Roof-mounted, booth-mounted

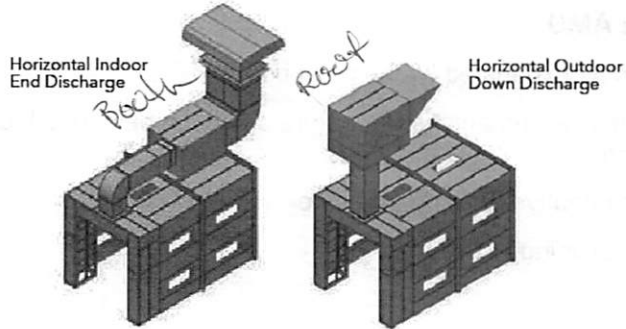

- Vertical - With stand, enclosed

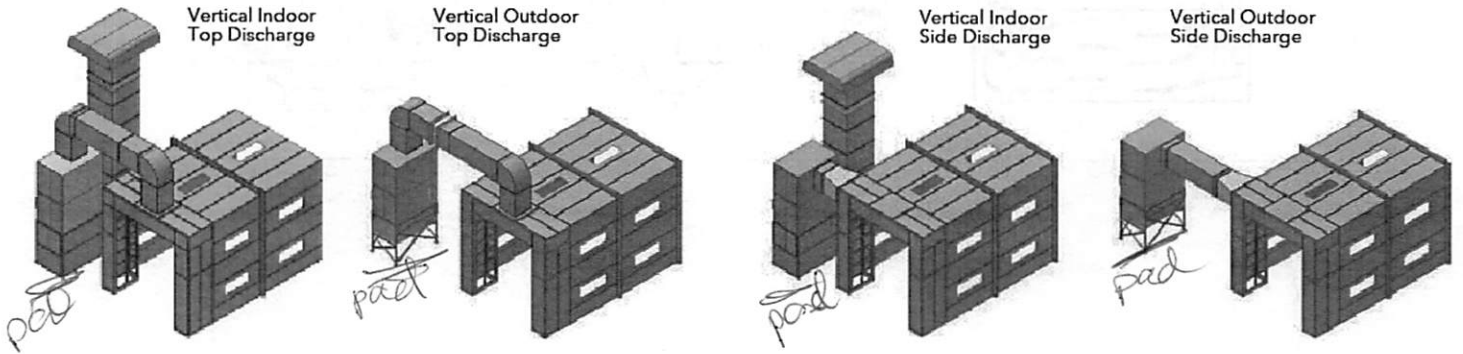

NOTES:

## AMU Types

- Indoor/Outdoor
- Direct fired
  - Indirect, electric, steam, hot water
- Gas
  - ✓ ○ LP gas
  - ✓ ○ Natural gas

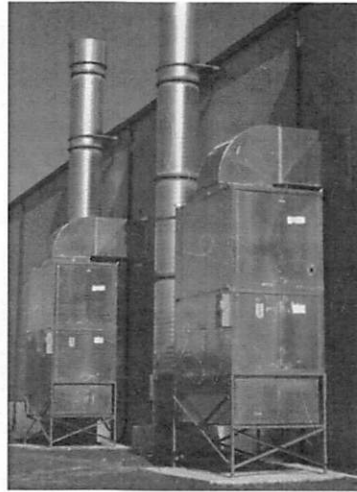

---

NOTES:

\* type of booms this is for.

### Variable Air Volume (VAV) Curing

During the cure cycle, VAV reduces CFM spray velocities by an average of 50 percent and allows for increased air temperatures of 140 to 160 degrees on average

- Enables temperature control during both the spray application and curing cycles
- Increases productivity by accelerating drying times
- More cost effective and more efficient
- Temperature control helps bond the paint to the object being painted

---

NOTES:

VFD  
pressurized  
any size.  
GP → Std on these.  
LE →

# An Option

---

## Recirculation

- Recirculate the air in bake mode
- Heating air that is already heated is much more efficient
- Accomplished with a Dampening System in the Air Make-Up Unit (AMU)

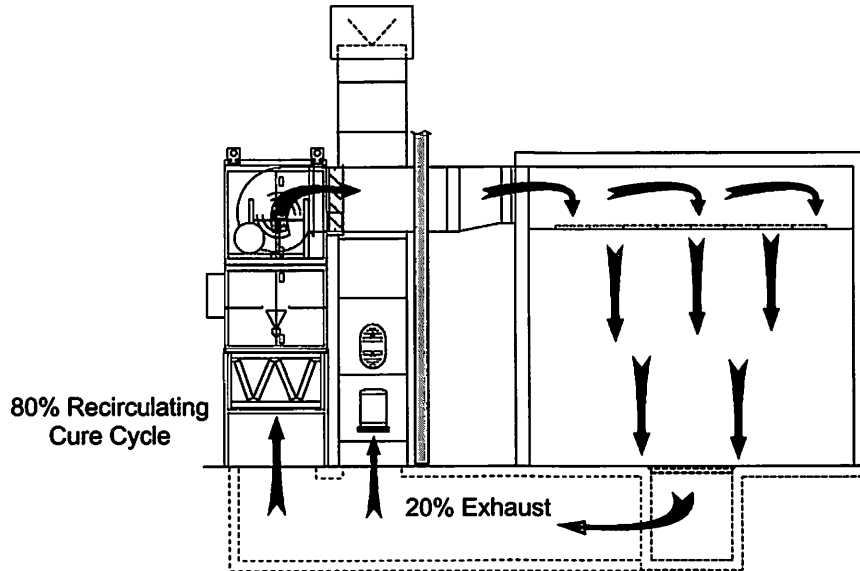

---

NOTES:

## Two Types of Heating Systems

Direct

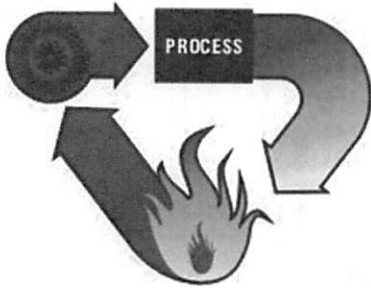
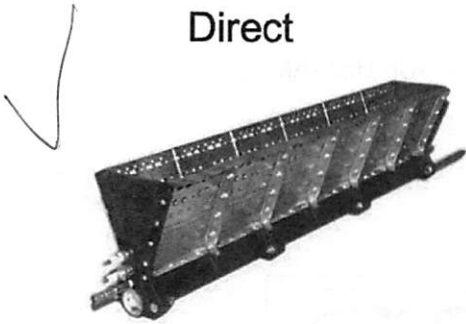

Indirect

*not efficient*

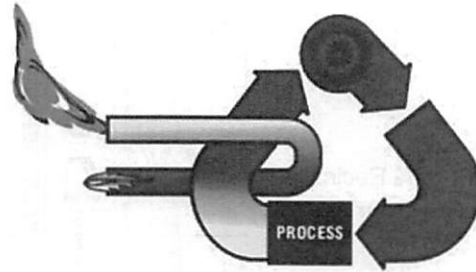
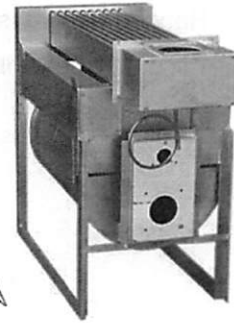

NOTES:

↓  
*bomb  
builders, etc  
no gen flames*



# Heating Efficiency

## Direct vs. Indirect Fired Burners Cure Temperature Rise

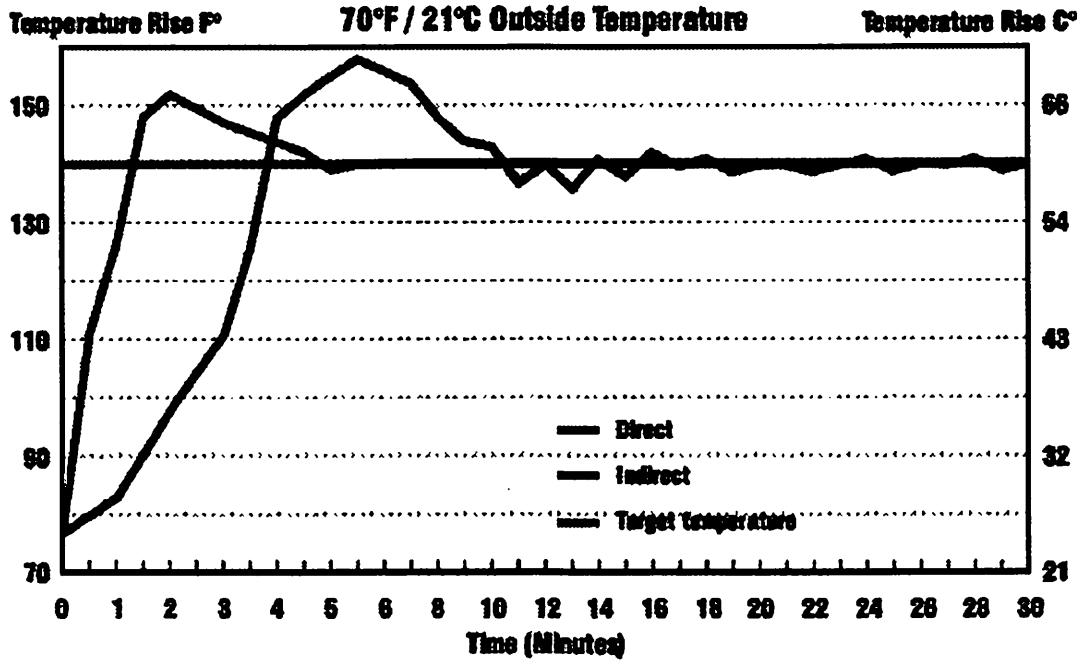

NOTES:

# GFS INDUSTRIAL PAINT BOOTHS

## Dry Filter - Open Face & Bench Booths

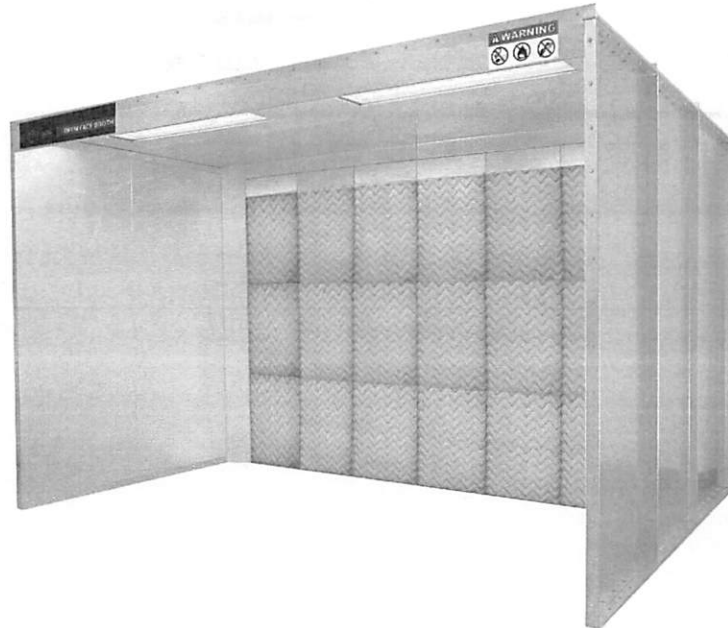

---

NOTES:

## Dry Filter - Enclosed Finishing Booths

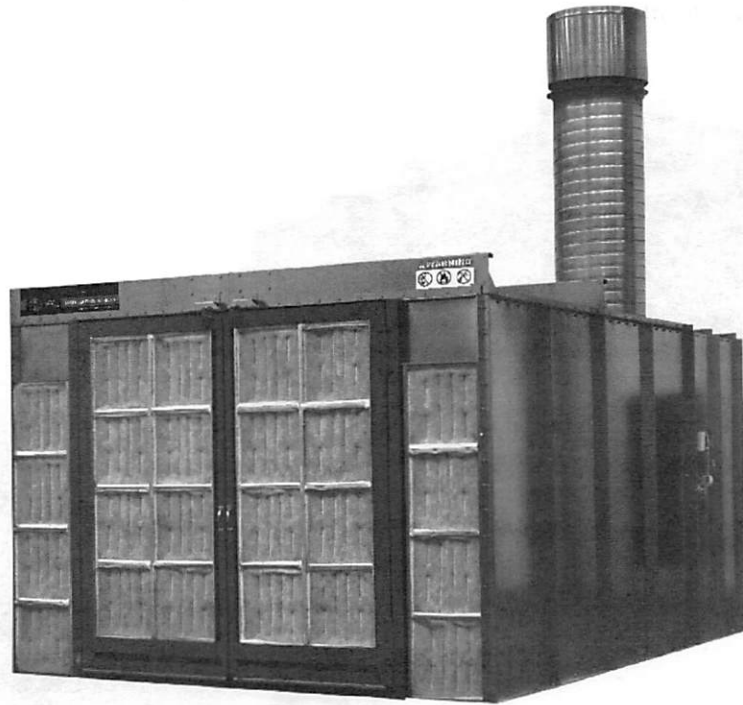

---

NOTES:

GP

## General Purpose Booths

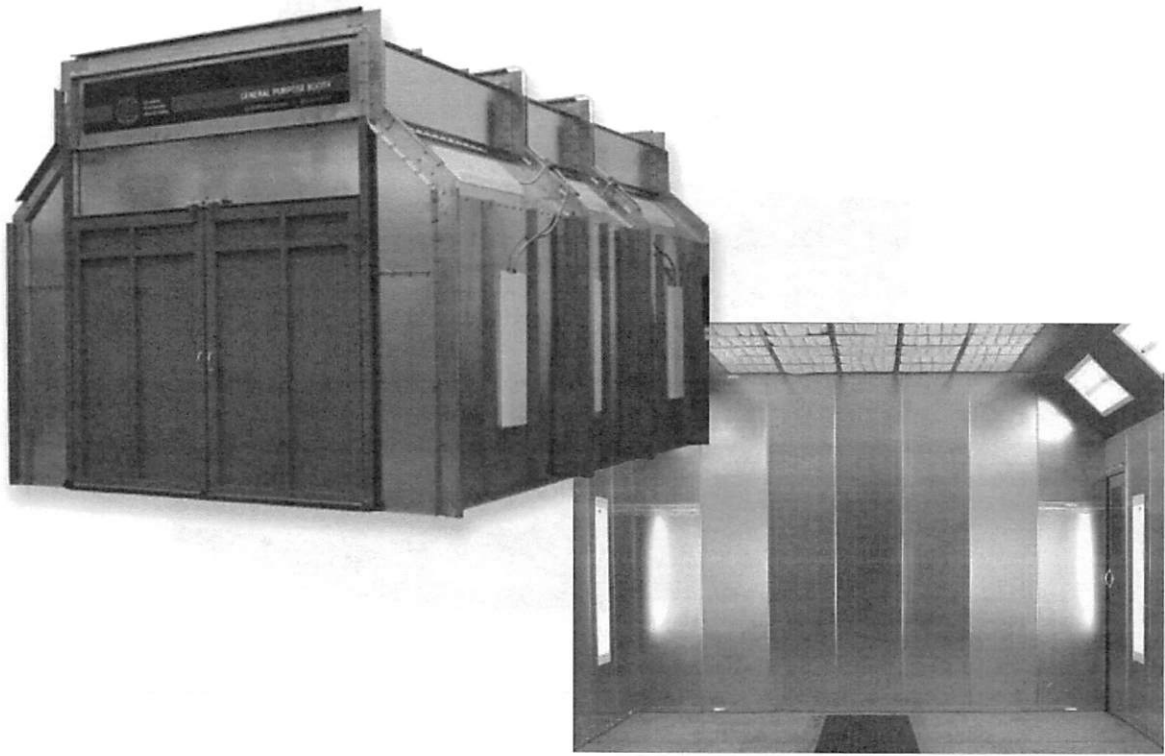

---

NOTES:

LE

## Large Equipment Booths

DA ES 10000 10000 10000 10000



---

NOTES:

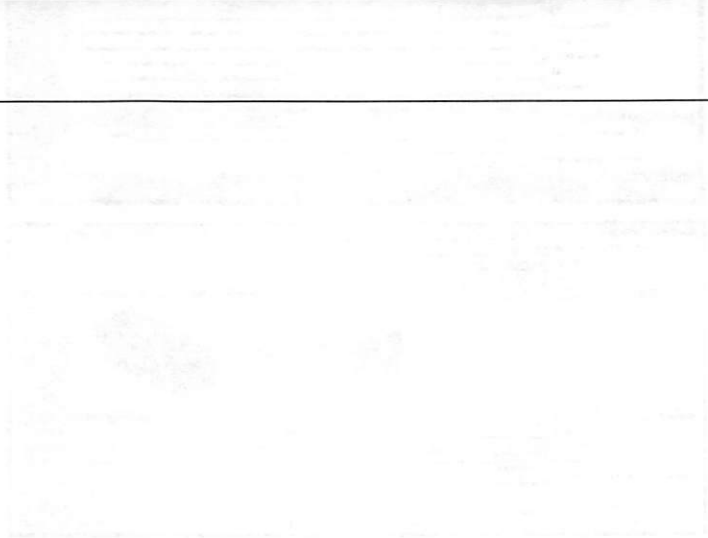

# SALES QUOTING TOOLS

## Sales Order Configurator Tool

- Instant access to pricing for pre-engineered paint booths and accessories
- Includes drawings
- Price and quote up to three pieces of equipment at the same time

### Tips:

- All required fields are highlighted in yellow
- Before selecting the equipment type, ensure all customer information is complete

**CONFIGURATOR TOOL**  
Industrial Products

Model Additional Info: Please Use ALL YELLOW Sections

Working Width	Working Depth	Working Length	Body Width	Body Height	Equip Depth	Type	Panel Type	Panel Finish	Structure	Make Style	EW	REV: 07062017
---------------	---------------	----------------	------------	-------------	-------------	------	------------	--------------	-----------	------------	----	---------------

Customer Information:  
Contact: \_\_\_\_\_  
Address: \_\_\_\_\_  
City: \_\_\_\_\_ State: \_\_\_\_\_ ZIP: \_\_\_\_\_  
Phone/Fax #: \_\_\_\_\_  
Email: \_\_\_\_\_

Distributor Information:  
PO Date: \_\_\_\_\_  
PO#: \_\_\_\_\_  
Distributor Name: \_\_\_\_\_  
Subsystem: \_\_\_\_\_  
Distributor Address: \_\_\_\_\_  
City: \_\_\_\_\_ State: \_\_\_\_\_ ZIP: \_\_\_\_\_  
Phone/Fax #: \_\_\_\_\_  
Email: \_\_\_\_\_

EQUIPMENT SELECTION  
Select By Equipment Model: \_\_\_\_\_ select  
OR  
Select By Equipment Type: \_\_\_\_\_ select

NOTES / INSTRUCTIONS  
Design for Integration Understanding Only

BASE MODEL PRICE: \_\_\_\_\_

EQUIPMENT SELECTION  
Select By Equipment Type: Large Equipment Booth select  
Select Equipment Style: Cassidraft ProPaint1200 Large Equipment Booth select  
Select Size: 14' W x 18' H x 20' L select

NOTES / INSTRUCTIONS  
Design for Integration Understanding Only

BASE MODEL PRICE: \$24,372

AMU OPTIONS

AMU Option	AMU Option Price	AMU Option Price
Add AMU: select AMU or Custom AMU (Contact G14 for Pricing)		
AMU Configuration: Vertical Outboard Side Discharge select configuration (price includes parts and labor)	\$21,410 ea	\$29,410
Control Voltage: select 120v or 240v select system voltage	\$7,575 ea	\$7,575
Approx. Distance from Booth to Edge Wall: 0 (To Prevent Fall) Recommended Distance between Booth Side Wall: 3		
Direct Fire Part Type: Natural Gas select AMU 000 Select this Pressure: 18.75 (PSIG)	\$180 ea	\$180
Canadian Requirements: select YES	\$655 ea	\$655
Add AMU Intake and Discharge Duct to: YES select YES Add Roof/Wall Flange: YES	\$3,300 ea	\$3,300

NOTES:

## Request for Quote (RFQ) Tool

The RFQ tool is used for generating quotes for custom equipment that is not available on the configurator tool

- Custom paint or powder booths
- Finishing systems
- Ovens
- Washers
- Air Make-Up Units (AMUs)
- Paint Mix Rooms
- Hazardous Material Storage Buildings

REQUEST FOR QUOTE - SPRAY BOOTH		File
Please Fill All Grey Highlighted Sections		
CONTACT INFORMATION	<i>Contact Information</i>	
	Date	<input type="text"/> enter
	Requestor Name	<input type="text"/>
	Distributor Name	<input type="text"/>
	Email Address	<input type="text"/> Phone Number <input type="text"/>
	End User Name	<input type="text"/>
	Install Location City	<input type="text"/>
	Install Location State	<input type="text"/> select
Type of Quote	<input type="text"/> select	
Engineering Stamp Required	<input type="text"/> Y/N	
PROJECT REFERENCE	Project Reference	
<input type="text"/>		
EQUIPMENT INFORMATION	<i>Equipment Information</i>	
	Quantity	<input type="text"/> enter
	Equipment Type	<input type="text"/> select
	<i>Standard</i>	
	Airflow Style	<input type="text"/> select
	<i>Standard</i>	
	Pressurized Booth	<input type="text"/> Y/N
	<i>Standard</i>	
	For Outdoor Use	<input type="text"/> Y/N
	<i>Standard</i>	
	Pressurized By	<input type="text"/> select
	<i>Standard</i>	
	Booth Finish	<input type="text"/> select
<i>Standard</i>		
Booth Panel Type	<input type="text"/> select	
<i>Standard</i>		
Booth Style	<input type="text"/> select	
<i>Standard</i>		
Pit Grating Type	<input type="text"/> select	
	<i>Width</i> <i>Height</i> <i>Depth</i>	
1A.RFQ 1B.CONVEYOR +		

NOTES:

Paint Booth Basics 101

Paint Booth Basics 101

Paint Booth Basics 101

Paint Booth Basics 101

Paint Booth Basics 101

Paint Booth Basics 101

Paint Booth Basics 101

Paint Booth Basics 101

Paint Booth Basics 101

