



**Modular design lets
you select the right pieces
for a perfect fit**



**Buying Guide
For Industrial
Air-Blast Cabinets**

STANDARD PRO-FINISH FEATURES

No other blast cabinet on the market today offers the many practical benefits included on a Pro-Finish cabinet as standard equipment. Just look at the features. The standard components in a Pro-Finish system have been carefully designed for safety, ease of operation, reduced maintenance and increased productivity. Throughout, these cabinets are built to meet the challenges of non-stop industrial blasting.

A

Dust collector features an energy-saving air-filtration system that captures 99% of all particles one micron or larger so cabinet ventilation can be recirculated. Fan is mounted on dust collector rather than reclaimer to prevent abrasive wear to the fan housing and impeller.

Cartridge dust collectors, offering improved efficiency and durability, are also available in 600, 900 and 1200 CFM models to simplify cleaning and maintenance.

B

Tunable reclaimers can be adjusted to control media size. Externally adjustable tuning band requires no tools and controls the size of fines extracted from the blast media. Screen prevents oversized particles from causing clogging and an easy access door permits quick filling.

C

One-cubic-foot pressure vessel minimizes refilling time and seals automatically for fast, easy startup. Construction is ASME coded only.

D

Rigid, dual-panel doors stand up to abrasives and seal more tightly than single-panel doors. Flush construction minimizes media spill when the door is opened.

E

Safety-door switch (Patent No. 4,505,077) prevents accidental blasting when doors are open. Complies with OSHA requirements.

F

Self-adjusting door latch assures continued tight sealing as door gasket ages.

G

Simple, pneumatic controls deliver greater reliability than electric controls employing limit switches and solenoids that often stick and burn out.

H

Wide foot treadle enables operation with either foot.

I

Moisture separator improves efficiency and reduces downtime by helping to prevent oil and moisture in supply lines from contaminating media.

J

Large, safety-glass window (14"x22") can be changed in a few minutes without tools and has rounded corners for safe handling.

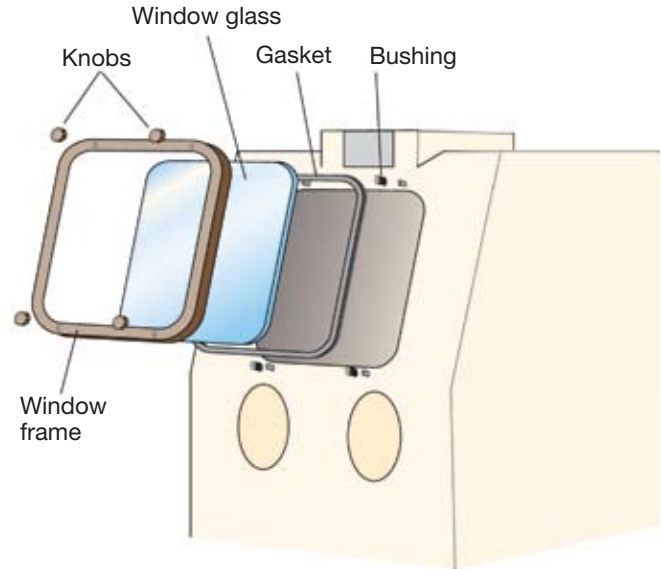

K

Kleensweep™ creates an air stream across the viewing window to reduce dust buildup and improve visibility.

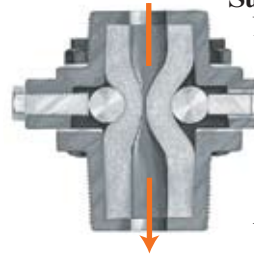

Sure-Flo® media regulator (Patent No. 4,518,145), used on pressure cabinets, is easy to adjust and assures precise media regulation, as well as continuous flow.

These regulators have excellent wear characteristics and, once the metering tube is worn, it can be easily replaced more quickly and economically than in any other media regulator on the market.

High-intensity flood lights reduce the chances of over blasting caused by poor visibility. Lights can be tilted to focus illumination on areas being blasted. Two lights are supplied on 2636, 3648 and 4848 models; three are provided as standard on 6060 and 7272 cabinets.



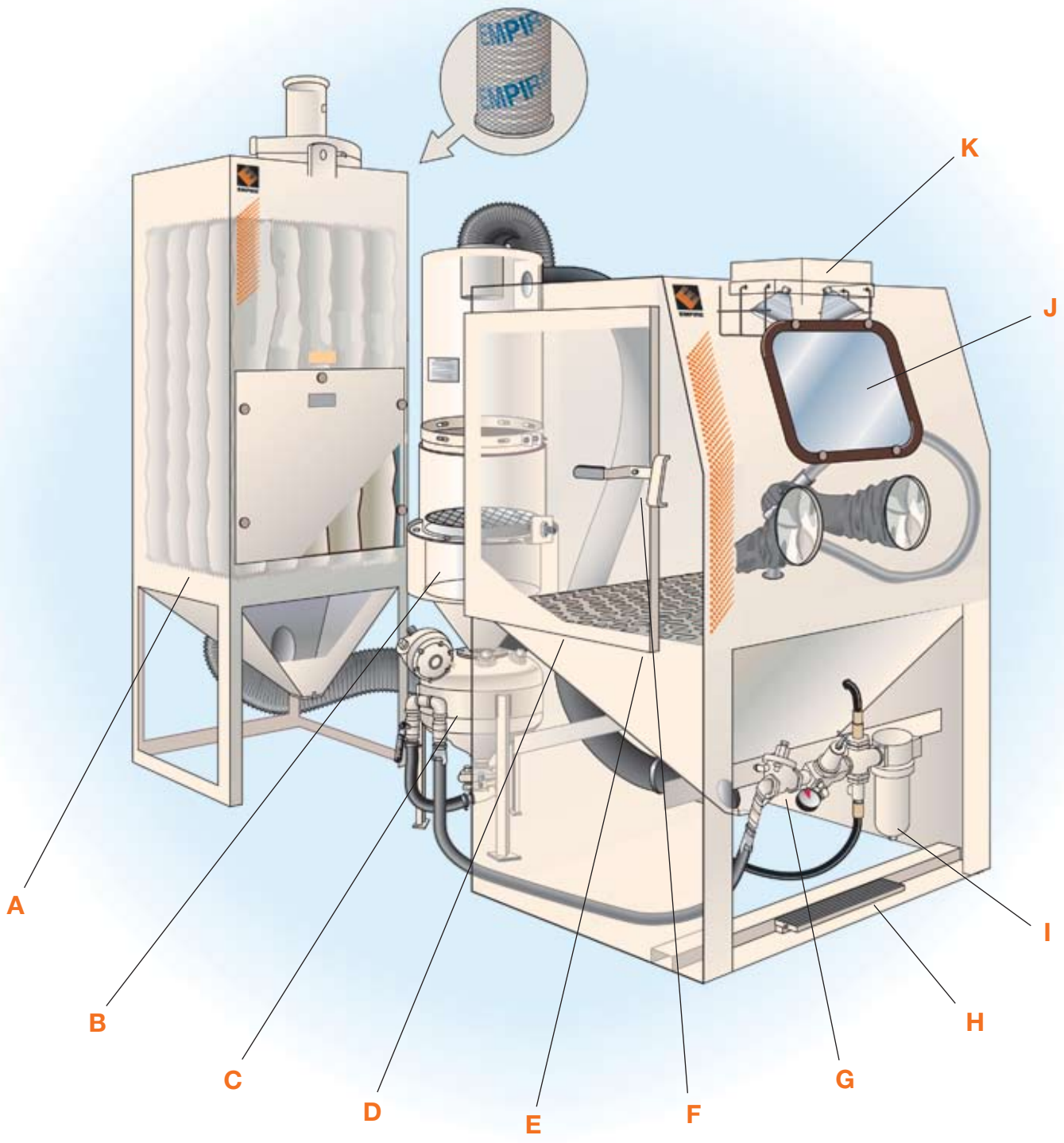

WHY YOU SHOULD CHOOSE A PRO-FINISH® SYSTEM

If your operations involve cleaning with chemicals, acid etching or dipping, liquid honing, wire brushing, sanding, deburring, grinding or peening, odds are a Pro-Finish system will save you time and money.

- These cabinet systems, designed for non-stop blasting, increase production rates because blasting is faster than other manual methods.
- Their versatility enables you to perform multiple tasks, ranging from blending surface flaws to removing foreign matter, such as carbon from pistons, without affecting tolerances. By simply varying air pressure and blast media, you can clean orpeen and do a lot in between.

- Modular design, including many standard factory options, lets you select a system that's just right for you—without paying for features and accessories you don't need. Pro-Finish also gives you the choice of a suction or pressure blast system.

- Blasting eliminates the environmental hazards associated with chemical finishing because most modern blast media are non-caustic and non-toxic. Plus, Pro-Finish systems put the emphasis on safety in mechanical ways with features such as blasting interlocks on cabinet doors, rounded corners on safety-glass viewing windows and guards on sharp floor edges, just to list a few.

OPERATING PRINCIPLES

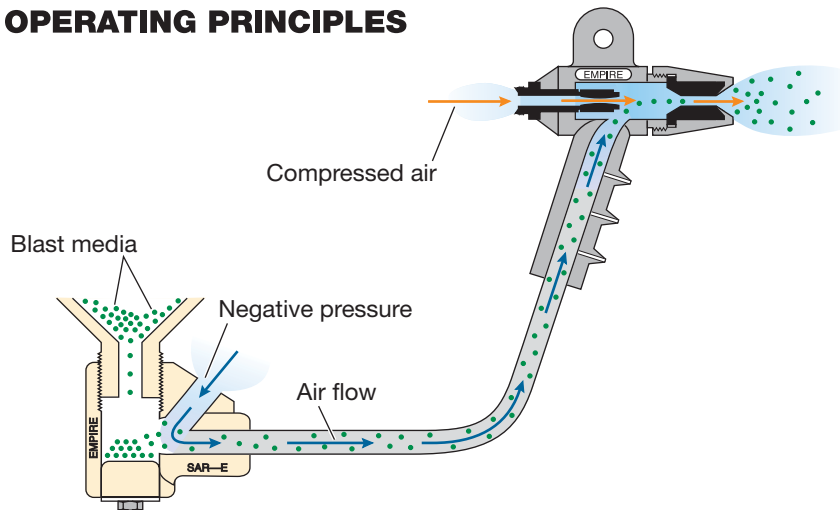

SUCTION SYSTEMS

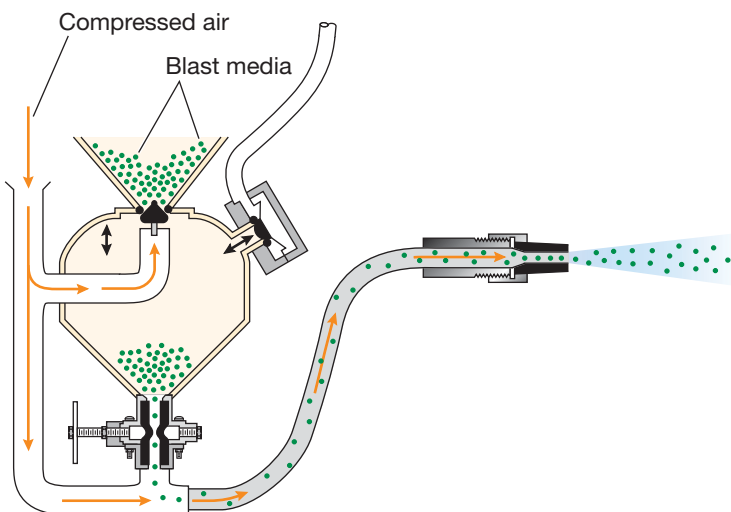

PRESSURE SYSTEMS



OPPORTUNITIES TO AUTOMATE

Powered movement of blast nozzles and/or workpieces automates air-blasting operations to varying degrees. For instance, using a powered turntable in combination with oscillating nozzles makes many blast-finishing processes virtually automatic when a timer package is added to control duration and on/off functions. Some techniques for automating Pro-Finish cabinets—easily and economically—are described below.

Turntables

Turntables, offered in both manual and pneumatically powered models, facilitate the handling of heavy parts and provide opportunities for automation. Turntables can be wheeled into or out of cabinets on a dolly or track, or fixed inside cabinets. Most stationary designs feature a low-profile, giving operators easy “over-the-top” access without wasting interior cabinet space.

Turntable sizes range from 18 to 48 inches in diameter with load capacities of up to 1,500 pounds. (Turntables with higher capacities are also available.) Powered turntables, with speed ranges from 8-to-20 rpm, can be controlled by a manual on/off valve or tied into an optional timer circuit for purposes of automation.

Gun Oscillators, Timers & Other Accessories

Gun oscillators, suitable for larger Pro-Finish cabinets, can be used with powered turntables and multiple nozzles to reduce the number of guns required, therefore reducing compressed-air consumption. The oscillator will blend multiple passes of the nozzle, creating a more uniform finish. Production rates increase as the benefits of manual coverage and multi-gun blasting are combined.

A radially sweeping oscillator, powered by an air cylinder, strokes as many as four blast guns through a range of up to 18 inches. Stroke length, stroke speed and on/off functions can also be controlled automatically.

Timers are employed to control the on/off functions of blast guns, oscillators and turntables. Our **60-minute spring timer** is powered mechanically and works well in most automated applications. Empire’s **precision reset timer**, powered by a synchronous motor, always clicks down from the same preset time. This feature, along with large graduations on the timer dial, assure more accurate control of blast durations.

When using timers with pressure systems, an adequate media supply must be available for the duration of the blast process. Consequently, a larger pressure vessel and/or media-level indicator should be considered.

Automatic door clamps lock the cabinet during blasting. For environments in which passive dust emissions present a safety concern, a timer is added to allow for adequate dust evacuation before the cabinet doors are opened. When “close-to-clean-room” standards are required, delay switches are supplied.

TYPE OF TURNTABLE	CABINET MODEL				
	2636	3648	4848	6060	7272
18" Manual with Dolly & Track (300 lb)	√				
24" Manual with Dolly & Track (1000 lb)		√	√	√	
36" Manual with Dolly & Track (1000 lb)			√	√	
48" Manual with Dolly & Track (1500 lb)					√
18" Manual, Fixed inside (300 lb)	√	√	√	√	√
24" Powered, Fixed inside (300 lb)		√	√	√	
36" Powered, Fixed inside (300 lb)			√	√	√
24" Powered with Dolly & Track (1000 lb)		√	√	√	
36" Powered with Dolly & Track (1000 lb)			√	√	√

√ Available with model number shown above



Turntables speed up parts handling and open avenues to automation.

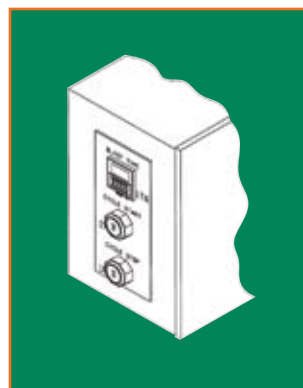

Precision reset timer controls blast duration and helps deliver consistent results.

SUCTION CABINETS

Pro-Finish suction cabinets cost less and are simpler than pressure cabinets. They also blast continuously without the need to stop for media refills, and they simplify the use of multiple nozzles. The results are usually comparable to those achieved with a pressure system although production rates are not as high. When initial cost and maintenance are primary concerns, the suction system is a good choice.

Pro-Finish suction systems come in five sizes and can be specified with a collector or dust bag on smaller units.

A media reclaimer is optional. Nevertheless, when using media that can be recovered, a reclaimer is advisable because it normally pays for itself quickly in terms of reduced waste and high-quality, repeatable results.

Pro-Finish suction cabinets are available with many factory options that contribute to ease of operation, reduced maintenance and greater productivity.

Plus, Pro-Finish's modular design lets you upgrade to a pressure system in the field at any time, enabling you to build on your original investment.



SB (Suction with bag)



SRB (Suction with reclaimer and bag)



SRC (Suction with reclaimer and collector)



SC (Suction with collector)

Suction-Blast Air Requirements (SCFM)

Pressure (PSI)	30	40	50	60	70	80	90	100
1/4" nozzle, 3/32" air jet	6	7	8	10	11	12	13	15
1/4" nozzle, 1/8" air jet	10	12	15	17	19	21	23	26
5/16" nozzle, 5/32" air jet*	15	19	23	27	31	37	38	42
7/16" nozzle, 7/32" air jet	31	38	45	52	59	66	73	80

*Unless otherwise specified, this nozzle is supplied.

4 SCFM = 1 compressor horsepower.

Suction-Blast Spray Diameters

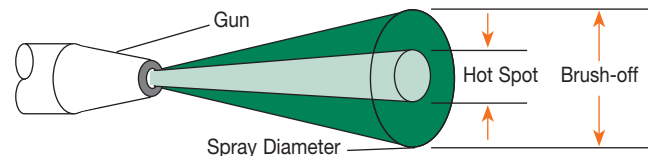

Gun ID	Distance from Workpiece					
	6"	6"	12"	12"	18"	18"
1/4"	1-3/8"	2-5/8"	-	2-3/4"	-	1"
5/16"*	1-1/2"	3-1/2"	1-3/4"	4-1/2"	-	3-3/4"
7/16"	2"	3-3/4"	2"	4-1/2"	-	3-3/4"

* Standard nozzle

Brush-off

Hot Spot

SUCTION BLAST OPTIONS

Multiple blast guns add to the speed and versatility of Pro-Finish suction cabinets. A total of four guns can be employed to facilitate the automated blasting of parts with irregular profiles. In addition to short-handle guns, the multiple-gun option includes individual shut-off valves, a one-inch pipe string, required hoses, and holders for gun positioning. Multi-gun packages include a 4.5-cubic-foot media storage hopper with easy access for loading and media inspection.

Fixed gun holder is adjustable to position gun in any orientation so operator can use both hands to manipulate workpieces within the blast stream.

Rotating basket, which attaches to cabinet door, automates batch finishing of small workpieces. The basket attachment includes its own drive motor and 60-minute timer. In addition, it is removable, which helps in unloading of parts and permits the cabinet to be used for manual blasting of larger workpieces.

The basket attachment is typically used with suction cabinets, but may be fitted to a pressure system having adequate media supplies. It will handle 15 pounds or 200 cubic inches of “flowable” parts and can be specified with an abrasion-resistant coating for longer service life. Empire also produces dedicated basket-blasting machines in a variety of models and sizes.

Kleen package consists of trays mounted under the cabinet-door opening and a return hose on the suction media regulator. Door trays prevent dust, which clings to the cabinet doors, from dropping onto the floor when the doors are opened. If the blast nozzle plugs, the pressurized media will not spill out of the media-regulator air intake. Instead, it is routed to the blast cabinet.

Kleen-package door trays are also available with pressure blast cabinets.



Fixed gun holder frees operator to manipulate parts.



4.5-cubic-foot media storage hopper provides a large supply of abrasives to support up to four blast guns.

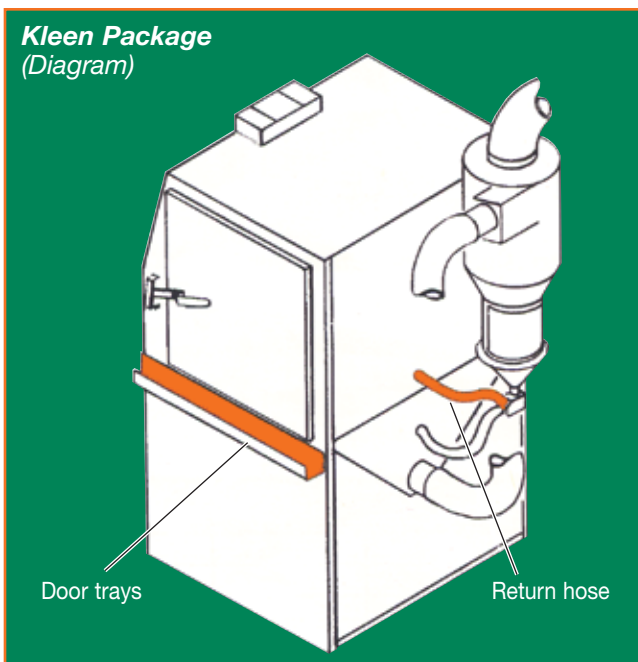

"Two-in-One" basket turns

Pro-Finish cabinet into a dual-purpose machine capable of finishing small parts automatically.

PRESSURE CABINETS

Because pressure cabinets deliver blast media at higher velocities than suction systems, a Pro-Finish pressure cabinet is ideal for turning out work fast. In many applications, these pressure cabinets will perform jobs four-times faster than suction systems. In addition, they use compressed air more efficiently and provide more precise blasting control at both high and low operating pressures. For really demanding tasks, like removing tight mill scale or finishing hard-to-reach surfaces, a pressure system is normally the only practical choice.

Pro-Finish pressure cabinets come in many sizes with dust collectors and media reclaimers provided as standard equipment. (Less expensive dust bags can be specified with some models—see specifications on pages 16 and 17.)

With Empire reclaimers, Pro-Finish pressure cabinets not only reduce operating costs associated with the purchase and disposal of media, but also assure consistent results shift after shift. Plus, they are available with options designed to meet almost any production need.



PRC (Pressure with reclaimer and collector)



PRB (Pressure with reclaimer and bag)

Pressure-Blast Air Requirements (SCFM)

Pressure (PSI)	20	30	40	50	60	80	100	120
1/8" nozzle	6	8	10	13	14	17	20	25
3/16" nozzle*	15	18	22	26	30	38	45	55
1/4" nozzle	27	32	41	49	55	68	81	97
5/16" nozzle	42	50	64	76	88	113	137	152
3/8" nozzle†	55	73	91	109	126	161	196	220

*Unless otherwise specified, this nozzle is supplied.

†This nozzle supplied on FaStrip cabinets.

4 SCFM = 1 compressor horsepower

Compressors should be sized to the next larger nozzle to allow for nozzle wear.

Pressure-Blast Spray Diameters

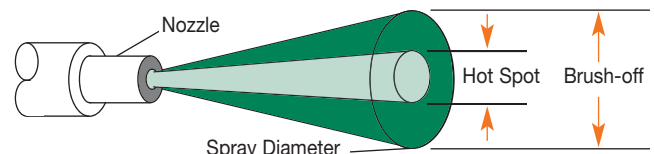

Nozzle ID	Distance from Workpiece					
	6"	12"		18"		
1/8"	3/4"	1"	1"	1-1/2"	-	1-1/8"
3/16"*	1-1/4"	1-3/8"	1-1/2"	2"	1-5/8"	2-1/2"
1/4"	1-1/4"	1-1/2"	1-7/8"	2-1/4"	2-1/8"	2-3/4"
3/8"†	1-5/8"	1-3/4"	2"	2-1/4"	2-1/4"	3"

*Standard nozzle

†FaStrip nozzle

Brush-off

Hot Spot



Fine-tuning controls let operator adjust air/grit ratio from front of cabinet for optimum results.

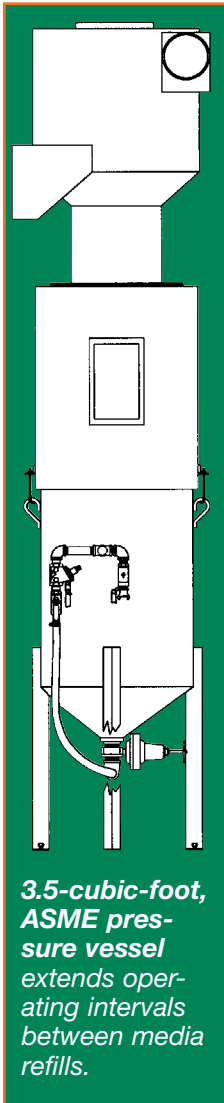

3.5-cubic-foot, ASME pressure vessel extends operating intervals between media refills.



Fixed-nozzle holder frees operator to manipulate parts.

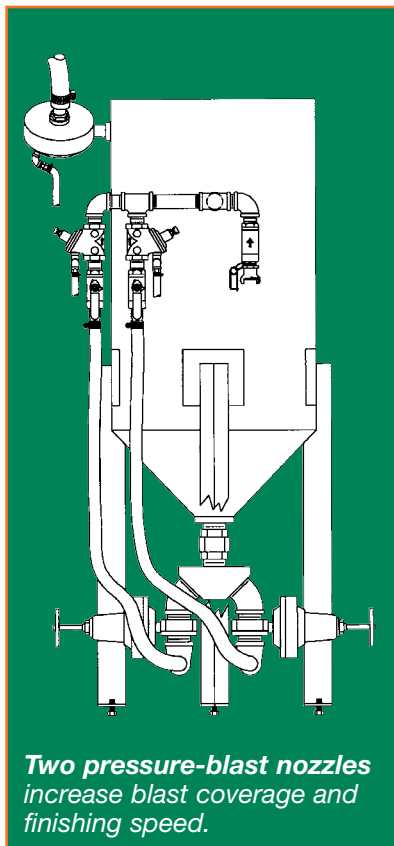

Two pressure-blast nozzles increase blast coverage and finishing speed.

PRESSURE BLAST OPTIONS

Fine-tuning controls, incorporating Empire's automatic Sure-Flo® media regulator, enable the operator to adjust the richness of the air-to-grit mixture from the front of the cabinet while he works. As a result, dialing in the optimum air-to-grit ratio for a particular job is greatly simplified. To further assist the operator, an indicator displays relative grit richness within the blast stream.

In applications where media are changed frequently—or where contamination can cause periodic clogging of the grit valve—a push-button choke is available on the same control panel.

Fixed-orifice media regulator is attached below the Sure-Flo valve in applications, such as shot peening, where very precise metering is required.

Low media-level sensor and indicator warns the operator when the media supply in the pressure vessel is low.

3.5-cubic-foot pressure vessel triples the amount of blasting that can be accomplished between media refills. This larger vessel is especially valuable when using a large blast nozzle or a second nozzle, it comes with a three-cubic-foot media-storage hopper, mounting brackets and longer hoses.

Two pressure-blast nozzles can be supplied with Pro-Finish systems to increase coverage and reach multiple faces on parts such as screw threads or root sections. Finishing speed is double that of an ordinary high-production pressure system. The two nozzles can be turned on and off individually with manual valves. Two holders are included for nozzle positioning.

Fixed-nozzle holder, which bolts anywhere on the cabinet wall, can be adjusted to position the nozzle in any orientation, leaving both of the operator's hands free to maneuver workpieces.

Pressure-conversion kits upgrade suction cabinets to pressure cabinets in the field.

NOTE: Some option combinations are not available. For information, please consult Empire or your local Empire distributor.

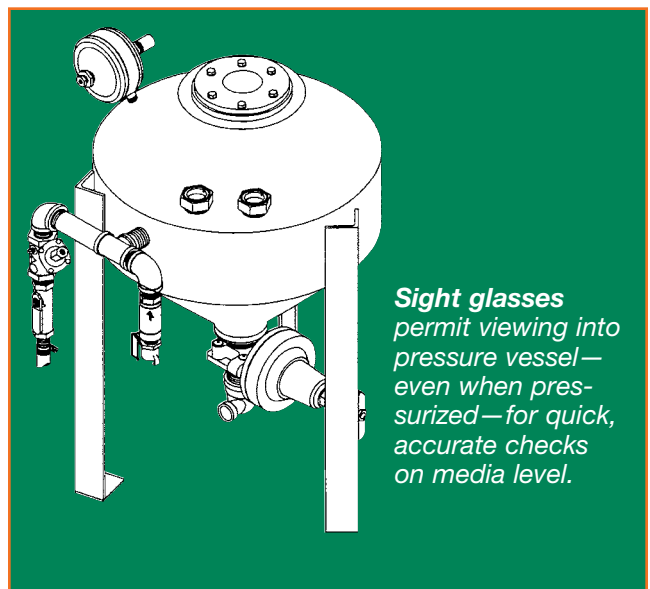

Sight glasses permit viewing into pressure vessel—even when pressurized—for quick, accurate checks on media level.



Rubber curtains, available in white to enhance visibility, protect the cabinet interior and are easy to replace.



Empire MH-2 blast guns or pressure nozzles are available with **tungsten carbide** or **silicon carbide** to reduce wear with certain types of media.

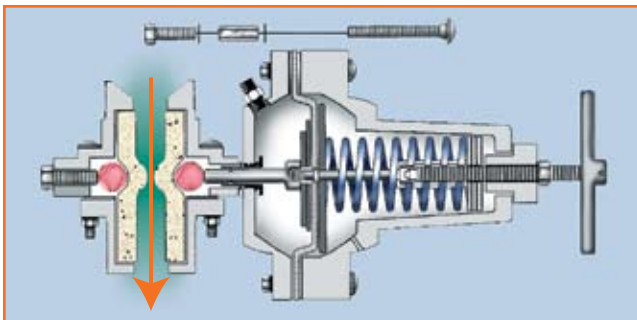

Automatic Sure-Flo media regulator promotes consistent media flow and reduces energy costs.

STANDARD PRO-FINISH OPTIONS

Pro-Finish cabinets are available with a wide range of factory options designed to reduce maintenance and improve operating efficiency. In addition, these cabinets can be automated to further enhance productivity and consistency. Nearly every option is easily retrofitted to existing systems.

Extended-Wear Components

Empire's extended-wear components increase service life in an aggressive or high-production environment. These components are normally very cost-effective because they reduce downtime as well as expenses for repairs and maintenance. Also, they are sold individually so you can tailor features to your specific application and budget.

The addition of **rubber curtains** increases cabinet life. These free-hanging liners, made of black 1/8" neoprene and held in place with rubber knobs for easy replacement, actually last longer than steel in an abrasive environment. White rubber is also available to brighten the cabinet interior. Beyond protecting the cabinet, these curtains resist discoloration much longer than white paint on steel.

Window protectors can be provided in clear plastic or a perforated screen to reduce clouding and pitting.

Matting is offered for turntables and cabinet floors to pad parts and prolong the life of steel-support surfaces.

Pro-Finish systems with reclaimers offer a number of protective options:

- **Heavy-duty, media-conveying duct** made of smooth-wall, wire-reinforced PVC for long service
- **Inlet wear-plate** (easily replaceable) to protect the most vulnerable part of the reclaimer
- **Urethane coating** that extends the service life of interior wear surfaces by five times
- **Ultra-wear lining**, as an alternative, that increases normal service life by a factor of ten

Di-Carb® nozzles (tungsten carbide) are available for use with steel abrasives and glass beads, as are **boron carbide nozzles** for applications involving aluminum oxide, silicon carbide and garnet.

Empire or your local Empire distributor can assist you in selecting the extended-wear components most beneficial in your air-blasting operations.

Media Control and Conditioning Options

For more efficient cycling of fine media, a **vibrating screen** can be added to the reclaimer on Pro-Finish suction systems. On pressure systems, Empire's **automatic Sure-Flo media regulator**, in combination with the **MG-78 CR exhaust valve**, can also be included to assure smooth, consistent operation. These devices overcome problems associated with very fine abrasives (200-300 mesh range), low-density media (e.g., plastics and walnut shells), and high humidity.

In addition, Empire's automatic Sure-Flo regulator conserves energy by retaining compressed air within the pressure vessel between shut-down and start-up.

ADDITIONAL CABINET OPTIONS

Pneumatically powered vertical-lift doors save floor space and facilitate loading and unloading of parts when used in combination with rolling turntable dollies. Several safety features assure the door will not close accidentally. A pneumatic sensor is also provided to prevent blasting whenever the door is open in accordance with OSHA standards.

Engineered for smooth operation, Pro-Finish vertical-lift doors are guided in plastic tracks. The door is fully sealed with gaskets to keep media inside the blast cabinet. Rubber lining and heavy-duty construction provide long service life.

Rubber safety mats, with holes to catch spilled particles, are placed around the blast cabinet to keep adjacent work areas clean and prevent injuries from falls, especially when slippery spherical media is used. The mats also dissipate static electricity, provide a comfortable surface on which to stand, and improve the appearance of the work area.

Cabinet sound attenuator, mounted over the air inlet, suppresses blasting noise from the cabinet by absorbing sound waves and directing them away from the operator.

Static strap, worn on the operator's wrist, dissipates static electrical charges, preventing shocks to the operator that may occur when humidity in the working environment is low.

System security key-lock, prevents use of the cabinet by unauthorized personnel. By retaining the key, supervisors are better able to keep track of why, when and by whom the system is being used.

DUST COLLECTOR OPTIONS

Fan sound attenuator reduces the noise level of Pro-Finish dust collectors below 85 db(A) in accordance with OSHA standards. These sound attenuators include a cover that can be adjusted to prevent light media from being carried through the system to the dust collector.

Automatic bag shaker signals a powered cylinder to automatically shake accumulated dust from the bags every time the machine is turned off. Several minutes of shaking cleans bags thoroughly, which extends their service life and improves visibility within the cabinet. Automation of this process also frees the operator for more productive tasks.

Manometer keeps the operator up to date regarding the cleanliness of the dust bags by registering the pressure drop across the bags whenever the fan is running.

Automatic pulse-check cleaner on CDC cartridge-type collectors assures thorough and timely cleaning for optimum performance.

Vertical-lift doors work smoothly and seal tightly to prevent media leaks. Plus, they are the safest in the industry.

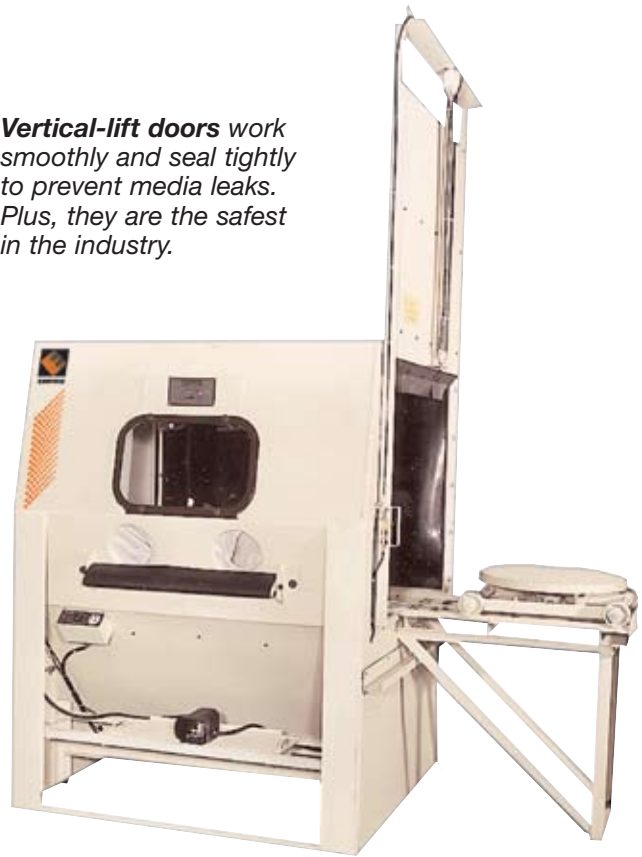

Fan sound attenuator on Pro-Finish dust collectors reduces noise levels below 85 db (A) in accordance with OSHA standards.

FaStrip® CABINETS

Pro-Finish FaStrip cabinets are specifically designed for use with low-density media, such as plastics, that provide fast coverage without eroding substrates. Paint stripping, for example, can be performed quickly and economically without the use of hazardous chemicals.

FaStrip cabinets deliver plastic or organic media from a large venturi nozzle coupled to a grounded, flexible blast hose. A large, vibrating screen within the reclaimer and Empire's exclusive automatic Sure-Flo media regulator, working in tandem with the MG-78 CR exhaust valve, keeps light media flowing smoothly. A magnetic separator is also included in the system to extract ferrous particles that can damage delicate substrates.



FaStrip cabinets remove old coatings quickly without damaging delicate substrates.

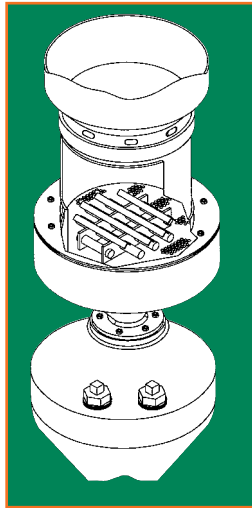

Magnetic separator extracts ferrous debris and can be removed easily for cleaning.

FaStrip Features

- Automatic Sure-Flo saves air, smooths media flow
- MG-78 CR exhaust valve improves media control
- Magnetic separator removes ferrous particles
- Vibrating reclaimer screen removes large debris
- Available in Ergo-Blast configurations

See pages 15 and 17 for available FaStrip models, part numbers, general specifications, shipping weights and dimensions.

ERGO-BLAST CABINETS

Empire offers a number of standard Pro-Finish variations for specialized air-blasting jobs.

Ergo-Blast systems, for instance, increase productivity by improving operator performance during extended periods of continuous blasting. These cabinets are ergonomically designed for sit-down operation and include other features to reduce fatigue. As a result, machine operators concentrate on the job at hand when working for hours on repetitive tasks rather than trying to find the best position to relieve a sore back. By removing everyday distractions, Ergo-Blast cabinets maximize production.

Ergo-Blast cabinets improve operator efficiency.



Ergo-Blast Features

- Knee-hole indentation for sitting operation
- Elevated foot rest for treadle control
- Elevated, padded arm rest that pivots
- Top-entry nozzle to take weight off operator's hand
- Cabinet sound attenuator
- Door trays to catch stray dust
- Available in FaStrip models

See pages 15, 16 and 17 for available Ergo-Blast models, part numbers, general specifications, shipping weights and dimensions.

ECONO-FINISH® CABINETS



These economical cabinets offer exceptional value when used in light-duty service. Despite their low cost, Econo-Finish cabinets can be specified with media reclaimers as well as dust-collection options approved by OSHA.

THE PRO-FINISH 7272

This cavernous cabinet will accept large parts, yet it is less expensive than a blast room, and it eliminates the need for operators to suit-up in protective clothing. In addition, the 7272 cabinet makes blasting surprisingly easy because the operator's gloves can be positioned at two different levels to accommodate variations in operator or workpiece height. Thanks to a dual-cone bottom, the floor height is quite low, enabling the operator to reach work surfaces without having to continually reposition parts in the blast enclosure.

Manufactured from 11-gauge plate steel with continuously welded seams, this rugged cabinet has a floor capacity of 1500 pounds. The blast hose enters from the top to relieve operator strain, and a serpentine media-return hose eliminates problems associated with the use of "Y" branches.

The unit shown is equipped with a powered door and parts-loading option consisting of a turntable dolly that rolls over tracks on the door's interior. Because the door is closed upward by a pneumatic piston, this assembly reduces vertical space requirements and provides an excellent seal. Double-winged doors are also available on 7272 cabinets without turntables.



SafeStrip™ CABINETS

SafeStrip™ cabinets contain the blast process during the cleaning and stripping of delicate surfaces. They are designed to work in conjunction with our SafeStrip portables as well as other pots capable of delivering fine media.

With a SafeStrip system, you can quickly and safely remove old coatings, dirt, oil, corrosion and other unwanted residues from soft metals, rubber, plastics and other sensitive surfaces. SafeStrip is ideal for work on tools, machine parts and molds, and in many other applications requiring a "light touch."



ProFormer™ Blast CABINETS

ProFormer™ cabinets put it all together in a single assembly that's easy to move and simple to hook up. These cabinets require only two connections, air and electrical. As part of our Pro-Finish line, they share exclusive Empire features including many standard factory options.



MODIFIED PRO-FINISH CABINETS



The Empire cabinet shown above provides a small glimpse of our versatility in modifying cabinets to meet specialized production requirements. With a vertical-lift door, a powered turntable and a hands-on work station, this unit integrates manual control with automation to exploit the best of both worlds—at a cost far less than custom engineering. Our modified Pro-Finish cabinets target specific production goals to boost your bottom line.

PRO-FINISH MEDIA RECLAIMERS

Media reclamation can be one of the most critical aspects of air-blasting processes. In addition to media costs, reclaimer performance affects operating speed and quality. Failure to remove dust and fines has an adverse effect on consistency and productivity. If oversized particles are returned to the blast system, for example, clogging and/or inconsistent results often occur.

Pro-Finish reclaimers provide precise control of media recycling. These reclaimers can be adjusted to control the recovery of fine, medium or coarse working materials while removing unwanted particles from the blasting process. As a result, you enjoy reduced media costs as well as consistent, high-quality results.

All Pro-Finish reclaimers deliver 99% efficiency, include a screen to prevent over-sized particles from

clogging, provide an easy-open access door for quick cleaning and filling, and feature 12-gauge construction for extended service life.

Media/Reclaimer Compatibility

RECLAIMER CFM	GLASS BEADS	ALUMINUM OXIDE	STEEL GRIT	STEEL SHOT
400	ALL	46	120	S-70
600	ALL	36	80	S-110
900	ALL	36	80	S-110
1200	ALL	30	40	S-170

Chart shows the maximum media sizes recoverable with single-gun/nozzle systems. Multiple guns, larger nozzles, operation at altitudes above 5000 feet, or use of a 50-Hz electrical supply may require a larger reclaimer and dust-collector blower. **Larger sizes may be used. Consult factory.**

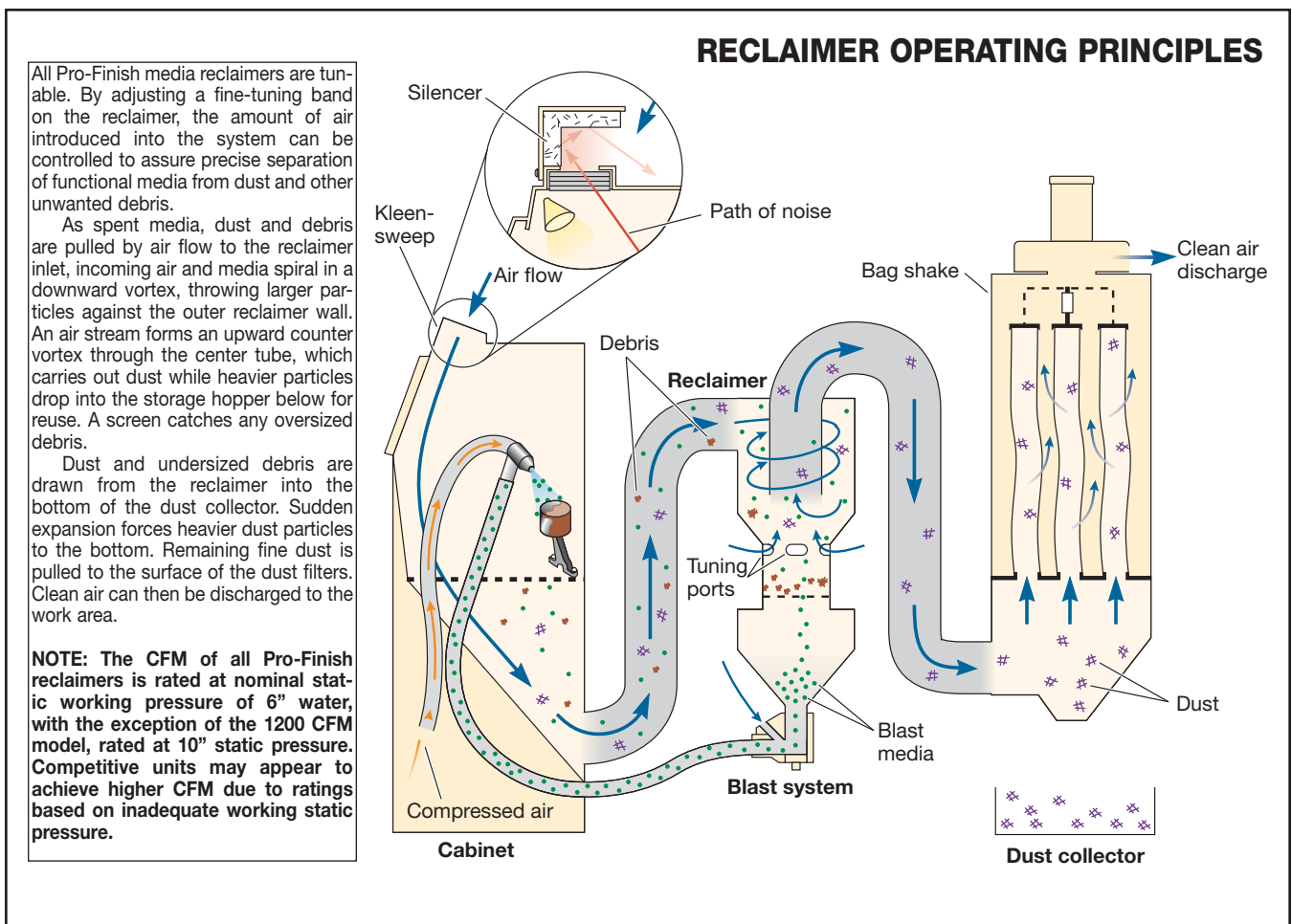

PRO-FINISH DUST COLLECTORS

Available in both bag- and cartridge-type designs, Pro-Finish dust collectors improve working conditions while reducing maintenance and operating costs. By capturing 99% of all particles one micron or larger, these efficient dust collectors permit filtered air to be recirculated into the plant, thus providing significant savings on heating and air conditioning.

Other features of Pro-Finish dust collectors include:

- Fan blade on clean-air side for long life
- 14-gauge, reinforced construction
- Raised clean-out opening for fast waste removal
- Top-clean air discharge for operator comfort
- Easy push-button control for thorough cleaning
- Cartridge models for simplified maintenance

PRO-FINISH DIMENSIONS

Standard Cabinets (See “SIDE VIEW” for A, B, C, D, E, and F. See “PLAN VIEW” for G, H, floor area and access points.)

CABINET MODEL SIZE	2636	3648	3674	4848	6060	7272
A) Door opening depth (ID)	20"	29"	29"	41"	50"	64"
B) Door opening height (ID)	22"	32"	32"	32"	40"	58"
C) Height from turntable to top of door opening						
Stationary manual turntable	17"	27"	—	27"	35"	—
Rolling manual turntable	15"	25"	25"	25"	33"	44"
Rolling powered turntable	—	21"	21"	21"	29"	38"
Low-profile turntable	20"	30"	—	30"	38"	—
D) Exterior height	72"	75"	75"	75"	80"	84"
E) Height from enclosure floor to glove-entry midpoint	10"	10"	10"	10"	10"	25" to 29"
F) Height from cabinet base to enclosure floor	34"	34"	34"	34"	34"	28"
G) Cabinet depth (exterior)	26"	36"	36"	48"	60"	72"
H) Cabinet width (exterior)	36"	48"	74"	48"	60"	72"
Floor area	42 ft ²	59 ft ²	90 ft ²	80 ft ²	87 ft ²	163 ft ²
Access points	*	*	*	*	*	*

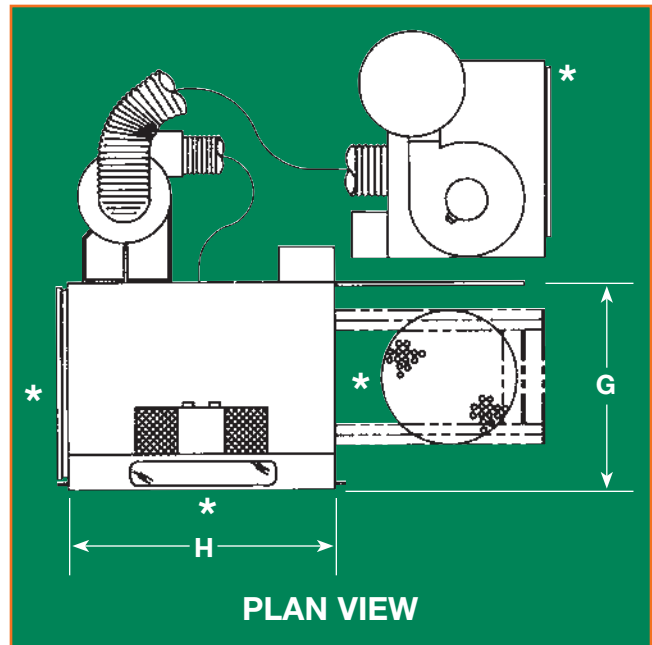
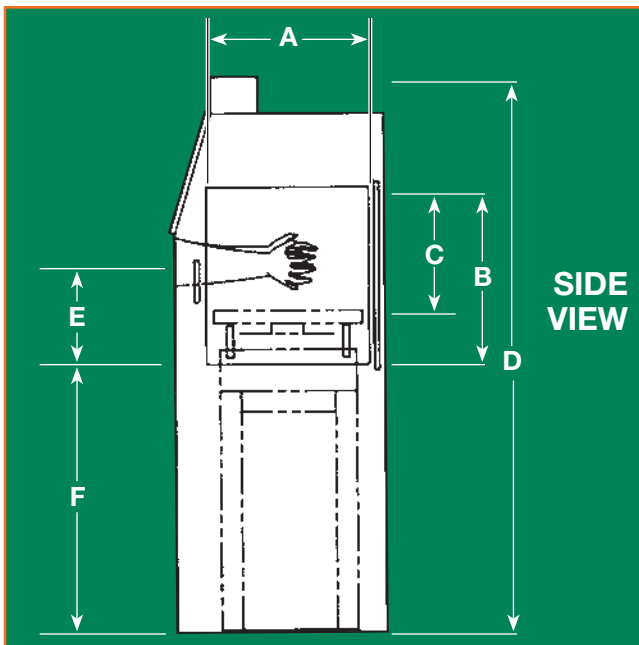

NOTES TO CABINET DIMENSIONS

- System shown includes cabinet, reclaimer, dust collector, turntable and some popular options. (Other configurations and options will affect dimensions, which are approximate and subject to change.)
- Dust collector, reclaimer and options can be rearranged within limits to suit particular installations.
- Floor areas shown indicate basic reclaimer/dust-collector sizes and include operator access points as well as turntable and platform.
- Height includes reclaimer and dust-collection hose.

Dust Collectors

MODEL	DCM-80A	DCM-200	DCM-200A	DCM-200B	CDC-6	CDC-9	CDC-12
Dimensions (DxWxH)	21"x26"x98"	34"x39"x107"	34"x39"x105"	34"x39"x116"	34"x39"x115"	34"x39"x115"	34"x39"x118"
With Sound Attenuator & Automatic Bag Shaker	29"x31"x107"	40"x41"x112"	40"x39"x112"	40"x39"x127"	—	—	—
With Sound Attenuator & Photohelic Package	—	—	—	—	34"x48"x120"	34"x48"x120"	34"x48"x123"

Dust Bags

Dimensions (DxWxH):	24"x30"x83"
---------------------	-------------

SUCTION CABINET SPECIFICATIONS

MODEL NUMBER	PART NUMBER	NUMBER OF DOORS	DUST COLLECTION	BLOWER MOTOR	SHIPPING WEIGHT
2636 SB	102010	1 standard	Dust bag	1 hp	421 lbs
2636 SC	102011	1 standard	DCM-80A	1 hp	671 lbs
2636 SRB-4	102000	1 standard	Dust bag	1 hp	451 lbs
2636 SRC-4	102001	1 standard	DCM-80A	1 hp	701 lbs
2636 SRC-4 (ERGO)	120001	1 standard	DCM-80A	1 hp	800 lbs
3648 SB	103010	2 standard	Dust bag	1 hp	539 lbs
3648 SC	103011	2 standard	DCM-80A	1 hp	789 lbs
3648 SRB-4	103000	2 standard	Dust bag	1 hp	565 lbs
3648 SRC-4	103001	2 standard	DCM-80A	1 hp	819 lbs
3648 SRC-4 (ERGO)	121001	2 standard	DCM-80A	1 hp	920 lbs
3648 SRC-6	103021	2 standard	DCM-200	1-1/2 hp	1266 lbs
3648 SRC-6 (CDC)	103051	2 standard	CDC-6	1-1/2 hp	1575 lbs
3648 SRC-6 (ERGO)	121021	2 standard	DCM-200	1-1/2 hp	1365 lbs
3648 SRC-6 (CDC, ERGO)	121051	2 standard	CDC-6	1-1/2 hp	1665 lbs
3674 SRC-9	128021	2 standard	DCM-200A	2 hp	1760 lbs
3674 SRC-9 (CDC)	128051	2 standard	CDC-9	2 hp	2060 lbs
3696 SB/TWIN	106010	2 standard	(2) Dust bags	(2) 1 hp	1078 lbs
3696 SC/TWIN	106011	2 standard	(2) DCM-80A	(2) 1 hp	1578 lbs
3696 SRB-4/TWIN	106000	2 standard	(2) Dust bags	(2) 1 hp	1138 lbs
3696 SRC-4/TWIN	106001	2 standard	(2) DCM-80A	(2) 1 hp	1638 lbs
3696 SRC-4/TWIN (ERGO)	124001	2 standard	(2) DCM-80A	(2) 1 hp	1840 lbs
3696 SRC-6/TWIN	106021	2 standard	(2) DCM-200	(2) 1-1/2 hp	2632 lbs
3696 SRC-6/TWIN (CDC)	106051	2 standard	(2) CDC-6	(2) 1-1/2 hp	3232 lbs
3696 SRC-6/TWIN (ERGO)	124021	2 standard	(2) DCM-200	(2) 1-1/2 hp	2850 lbs
3696 SRC-6/TWIN (CDC, ERGO)	124051	2 standard	(2) CDC-6	(2) 1-1/2 hp	3450 lbs
4848 SC	104011	2 standard	DCM-200	1-1/2 hp	1376 lbs
4848 SRC-6	104001	2 standard	DCM-200	1-1/2 hp	1423 lbs
4848 SRC-6 (ERGO)	122001	2 standard	DCM-200	1-1/2 hp	1525 lbs
4848 SRC-6 (CDC, ERGO)	122051	2 standard	CDC-6	1-1/2 hp	1825 lbs
4848 SRC-9	104021	2 standard	DCM-200A	2 hp	1458 lbs
4848 SRC-9 (ERGO)	122021	2 standard	DCM-200A	2 hp	1566 lbs
4848 SRC-9 (CDC, ERGO)	122052	2 standard	CDC-9	2 hp	1860 lbs
6060 SC	105011	2 standard	DCM-200A	2 hp	1669 lbs
6060 SRC-9	105001	2 standard	DCM-200A	2 hp	1736 lbs
6060 SRC-9 (CDC)	105051	2 standard	CDC-9	2 hp	2036 lbs
60120 SC/TWIN	107011	2 standard	DCM-200A	2 hp	3338 lbs
60120 SRC-9/TWIN	107001	2 standard	DCM-200A	2 hp	3472 lbs
60120 SRC-9/TWIN (CDC)	107051	2 standard	CDC-9	2 hp	4072 lbs
7272 SRC-9	127001	1 standard	DCM-200A	2 hp	2700 lbs
7272 SRC-12	127023	1 standard	DCM-200B	5 hp	2800 lbs

NOTES TO SPECIFICATIONS: All cabinet sizes feature 14-gauge steel construction with the exception of 7272 cabinets which are 11-gauge. Cabinets with a single door open on the right-hand side. (An additional left-hand door is optional.) For information on **electricals, reclaiming sizing and dust collection**, see “**APPLICATION CONSIDERATIONS**” on page 18.

MEANING OF MODEL NUMBERS AND LETTER CODES: The first two numbers indicate nominal cabinet depth in inches. The next two or three numbers show nominal cabinet width. Letters following model numbers mean the following: **S** = Suction; **P** = Pressure; **B** = Bag; **C** = Collector; **R** = Reclaimer. Numerals following letter codes show reclaimer-ventilation capacity in hundreds of CFM at 6” S.P. (1,200 CFM units are rated at 10” S.P.) “TWIN” indicates a two-cabinet system. (Example: a 60120 TWIN consists of two 6060 cabinets) Letter codes in parentheses translate as follows: CDC = Cartridge Dust Collector; ERGO = Ergo-Blast model; FS = FaStrip model.

PRESSURE CABINET SPECIFICATIONS (See facing page for meaning of model numbers and notes.)

MODEL NUMBER	PART NUMBER	NUMBER OF DOORS	DUST COLLECTION	BLOWER MOTOR	SHIPPING WEIGHT
2636 PRB-4	102100	1 standard	Dust bag	1 hp	664 lbs
2636 PRC-4	102101	1 standard	DCM-80A	1 hp	914 lbs
2636 PRC-4 (ERGO)	120101	1 standard	Dust bag	1 hp	1015 lbs
3648 PRB-4	103100	2 standard	Dust bag	1 hp	782 lbs
3648 PRC-4	103101	2 standard	DCM-80A	1 hp	1032 lbs
3648 PRC-4 (ERGO)	121101	2 standard	DCM-80A	1 hp	1130 lbs
3648 PRC-6	103121	2 standard	DCM-200	1-1/2 hp	1479 lbs
3648 PRC-6 (CDC)	103151	2 standard	CDC-6	1-1/2 hp	1779 lbs
3648 PRC-6 (ERGO)	121121	2 standard	DCM-200	1-1/2 hp	1585 lbs
3648 PRC-6 (FS)	103129	2 standard	DCM-200	1-1/2 hp	1500 lbs
3648 PRC-6 (CDC, ERGO)	121151	2 standard	CDC-6	1-1/2 hp	1885 lbs
3648 PRC-6 (CDC, FS)	103159	2 standard	CDC-6	1-1/2 hp	1800 lbs
3648 PRC-6 (ERGO, FS)	121921	2 standard	DCM-200	1-1/2 hp	1600 lbs
3648 PRC-6 (CDC, ERGO, FS)	121951	2 standard	CDC-6	1-1/2 hp	1900 lbs
3674 PRC-9	128121	2 standard	DCM-200A	2 hp	1970 lbs
3674 PRC-9 (CDC)	128151	2 standard	CDC-9	2 hp	2290 lbs
3674 PRC-9 (FS)	128129	2 standard	DCM-200A	2 hp	2300 lbs
3674 PRC-9 (CDC, FS)	128159	2 standard	CDC-9	2 hp	2600 lbs
3696 PRB-4/TWIN	106100	2 standard	(2) Dust bags	(2) 1 hp	1379 lbs
3696 PRC-4/TWIN	106101	2 standard	(2) DCM-80A	(2) 1 hp	1879 lbs
3696 PRC-4/TWIN (ERGO)	124101	2 standard	(2) DCM-80A	(2) 1 hp	2975 lbs
3696 PRC-6/TWIN	106121	2 standard	(2) DCM-200	(2) 1-1/2 hp	2773 lbs
3696 PRC-6/TWIN (CDC)	106151	2 standard	(2) CDC-6	(2) 1-1/2 hp	3373 lbs
3696 PRC-6/TWIN (ERGO)	124121	2 standard	(2) DCM-200	(2) 1-1/2 hp	2900 lbs
3696 PRC-6/TWIN (FS)	106901	2 standard	(2) DCM-200	(2) 1-1/2 hp	2750 lbs
3696 PRC-6/TWIN (CDC, ERGO)	124151	2 standard	(2) CDC-6	(2) 1-1/2 hp	3500 lbs
3696 PRC-6/TWIN (ERGO, FS)	124921	2 standard	(2) DCM-200	(2) 1-1/2 hp	2950 lbs
4848 PRC-6	104101	2 standard	DCM-200	1-1/2 hp	1636 lbs
4848 PRC-6 (CDC)	104151	2 standard	CDC-6	1-1/2 hp	1936 lbs
4848 PRC-6 (ERGO)	122101	2 standard	DCM-200	1-1/2 hp	1735 lbs
4848 PRC-6 (CDC, ERGO)	122151	2 standard	CDC-6	1-1/2 hp	2035 lbs
4848 PRC-9	104121	2 standard	DCM-200A	2 hp	1671 lbs
4848 PRC-9 (CDC)	104152	2 standard	CDC-9	2 hp	1971 lbs
4848 PRC-9 (ERGO)	122121	2 standard	DCM-200A	2 hp	1775 lbs
4848 PRC-9 (FS)	104129	2 standard	DCM-200A	2 hp	1650 lbs
4848 PRC-9 (CDC, ERGO)	122151	2 standard	CDC-9	2 hp	2075 lbs
4848 PRC-9 (CDC, FS)	104159	2 standard	CDC-9	2 hp	1950 lbs
4848 PRC-9 (ERGO, FS)	122921	2 standard	DCM-200 A	2 hp	1750 lbs
4848 PRC-9 (CDC, ERGO, FS)	122951	2 standard	CDC-9	2 hp	2050 lbs
6060 PRC-9	105101	2 standard	DCM-200A	2 hp	1949 lbs
6060 PRC-9 (CDC)	105151	2 standard	CDC-9	2 hp	2250 lbs
6060 PRC-9 (FS)	105129	2 standard	DCM-200A	2 hp	1975 lbs
6060 PRC-9 (CDC, FS)	105159	2 standard	CDC-9	2 hp	2275 lbs
60120 PRC-9/TWIN	107101	2 standard	DCM-200A	2 hp	3713 lbs
60120 PRC-9/TWIN (CDC)	107151	2 standard	CDC-9	2 hp	4313 lbs
7272 PRC-9	127101	1 standard	DCM-200A	2 hp	2900 lbs
7272 PRC-9 (FS)	127901	1 standard	DCM-200A	2 hp	3000 lbs
7272 PRC-12	127123	1 standard	DCM-200B	5 hp	3000 lbs
7272 PRC-12 (FS)	127923	1 standard	DCM-200B	5 hp	3100 lbs

APPLICATION CONSIDERATIONS

To specify the proper equipment for your application, you should set specific objectives and choose the equipment and materials to achieve these goals.

If you are replacing existing equipment or adding blast cabinets to meet growing needs, you are probably familiar with the benefits of air-blasting, the best media to use, and the type of system you want. However, if you have a new blasting application, you and your Empire distributor should review the following outline before making a final selection.

Cabinet Sizing

Prior to selecting a cabinet, determine the critical characteristics of your workpiece. These factors should include: part size (will the workpiece fit into the cabinet?), accessibility of surfaces to be blasted, orientation requirements, desired operating procedures (manual or automatic), and masking considerations. Normally, a sketch of the part within the cabinet is helpful in determining the most functional cabinet size.

Surface Requirements

To achieve desired results, there is no substitute for actual sample blasting, through which real-world parameters can be defined. The key factors in achieving the “right” surface characteristics are: coverage, duration, pressure and media—all of which are inter-related. Nevertheless, the best final results normally start with the “right” media. General descriptions and characteristics of the most commonly used blast media are provided on the back cover of this catalog.

Generally, fine media do faster work on lighter jobs. Heavy media impact harder for deeper etching or increased “arc heights,” but may lodge in small recesses. Before making a final choice about media, determine how many times the material can be recycled and how reclamation affects your operating costs.

Production Rate

The many variables affecting production rates include: blast system type (suction or pressure); blast media (type, size and quality); blast pressure; distance and angle of guns/nozzles in relation to the workpiece; part size; and operator capabilities. Again, sample blasting is the only true test, but if higher production rates are your objective, take a look at Pro-Finish pressure systems and Ergo-Blast configurations for manual work—or consider automation options.

Reclaimer and Dust Collector

Most Pro-Finish systems are available with two ventilation options. Dusty, heavy-use or multiple-gun applications usually require additional ventilation for optimum operator visibility and extended equipment life. Dense media require larger blowers for adequate conveying. (See “**Media/Reclaimer Compatibility**” table on page 14.) Systems with exposed dust bags or without reclaimers are not recommended for production applications.

Utilities

Your Pro-Finish system requires electricity and compressed air. Be sure the system you select interfaces properly with the electrical sources in the plant where it will be installed. Standard pre-wiring for 1 horsepower motors is: 115V, 60Hz, 1 phase, 20 amp; for 1-1/2 horsepower motors: 230V, 60Hz, 1 phase, 15 amp; for 2 horsepower motors: 230V, 60Hz, 1 phase, 17 amp; for 5 horsepower motors: 230V, 60Hz, 3 phase, 20 amp. These numbers represent full-amp draws for the dust collector and basic cabinet. Three-phase electrical upgrades can be supplied complete with control transformer for one-source power connection. Three-phase upgrades are also available with more economical dual source. Because field re-wiring can be costly, it is not advisable.

Options

Tailor the system to your application by choosing standard options. If harsh media is selected, you will want to protect your equipment with Empire’s extended-wear components. For light or fine media (200 mesh or less), or humid conditions, consider a vibrating screen and automatic Sure-Flo regulator. When using plastics or walnut-shells, FaStrip cabinets are recommended.

Review all standard factory options as they relate to material handling, productivity and serviceability with an eye toward getting maximum value from your Pro-Finish system. Because these systems are modular, you can select only the equipment needed. Further upgrading in the field is normally a simple procedure.

Automation

You can customize a Pro-Finish cabinet to run without an operator by incorporating a powered turntable and gun holder. More sophisticated approaches include multiple blast guns, oscillators and a timer package.

Almost every automated Pro-Finish application is different so care should go into visualizing how the part will be processed. If an out-of-round workpiece is rotated on a turntable, areas that come closer to a stationary blast source will experience greater intensity. In addition, recessed regions may be missed and interior surfaces may be hard to reach with standard equipment.

Multiple guns/nozzles not only provide faster cycles through increased coverage, but also “see” more facets on multi-sided parts. Consequently, most automated systems employ multiple guns or nozzles.

Manual touch-up is offered with Pro-Finish systems involving automation because, unlike the human eye, mechanical devices cannot sense where extra blasting might be required. Touch-up can also eliminate the effect of “barberpoling,” which occurs when blast oscillation is slightly faster than part rotation.

One of the final “components” to choose in your automated Pro-Finish system is the cabinet. Picture how much room is needed inside the working enclosure—not only for the workpiece, but also for the guns/nozzles, hoses and all moving mechanisms. Be careful not to undersize the cabinet.

A TRACK RECORD OF "FINISHING FIRST"



Shifter forks
etched with ALOX

Cylinder surface
profiled with ALOX



**Parts BEFORE and AFTER
air-blasting with EMPIRE
machines**



Copier tube
etched with silicon

Collar deburred
with glass beads



BEST-EQUIPPED TEST LAB AND DEMONSTRATION CENTER IN THE WORLD



Our test lab and demonstration center in Langhorne, PA, is the world's largest. It enables us to simulate many production conditions in order to determine the best mix of media and machinery for your application.

The variables we can adjust include media type, blast systems (suction or pressure), operating pressures, dwell times, impact angles and other factors related to fixturing and parts handling.

We can simulate the blast parameters you prescribe or we can develop recommendations on the best combination of media and equipment when you supply "before and after" sample parts.

EMPIRE: THE LEADER IN AIR-BLAST TECHNOLOGY

Empire continues to lead in the design and manufacture of air-blast equipment by sustaining the focus and ingenuity that spawned the company more than sixty years ago.

Today, Empire produces the world's most extensive line of air-blast products, including portable blasters, blast rooms, automated systems and blast cabinets in configurations to meet almost any requirement.

Within our Pro-Finish® cabinet line, you will find "All-in-One" ProFormer™ cabinets, SafeStrip™ cabinets for handling light media and a long list of cabinets modified for specialized applications—normally with a minimum of custom engineering.

We've earned our reputation as the leader in air-blast technology by developing products that meet customer needs for increased productivity and improved product quality—and by supporting our equipment with responsive training, service and testing programs.

When you require advice, assistance or equipment on short notice, our national network of stocking distributors assures that help is nearby.

To arrange a first-hand look at our operations, please give us a call.



Empire Abrasive Equipment Company, headquartered in Langhorne, Pennsylvania, specializes in the development of air-blast systems and equipment.

PRO-FINISH SURFACE-TREATMENT, CLEANING AND FINISHING CAPABILITIES

The selections of finishes are virtually unlimited and so are the applications.

<p>Finishing</p> <ul style="list-style-type: none"> • Add matte or satin finish, or decorative frost • Remove glare or imperfections • Blend marks • Hone and burnish • Mark identifications 	<p>Cleaning & Removal</p> <ul style="list-style-type: none"> • Chemical impurities • Paint • Sealants and adhesives • Carbon deposits • Excess brazing materials • Rust • Coatings • Scale • Casting • Flashing • Burrs • Oxidation 	<p>Surface Treatment & Prep</p> <ul style="list-style-type: none"> • Strengthen • Add fatigue resistance • Improve wear properties • Reduce design weights, porosity, friction or susceptibility to corrosion • Expose flaws for inspection • Etch for bonding and adhesion • Cut • Improve lubrication
--	--	--

MEDIA GUIDE

	Glass Bead	Ceramic Shot	Stainless Cut Wire	Steel Shot	Steel Grit	Aluminum Oxide	Silicon Carbide	Garnet	Crushed Glass	Plastic Media	Agri Shell
Finishing	YES	YES	YES	YES	YES	YES	YES	YES	YES	NO	NO
Cleaning/Removal	YES	YES	YES	YES	YES	YES	YES	YES	YES	YES	YES
Peening	YES	YES	YES	YES	NO	NO	NO	NO	NO	NO	NO
Surface Profiling (Etch)	NO	NO	YES	NO	YES	YES	YES	YES	YES	YES	YES
Working Speed	MED	MED	MED	MED	MED-HIGH	HIGH	VERY-HIGH	HIGH	HIGH	MED-HIGH	LOW-HIGH
Recyclability	HIGH-LOW	HIGH	HIGH	VERY-HIGH	VERY-HIGH	MED-HIGH	MED-LOW	MED	MED-LOW	MED	LOW
Probability of Metal Removal	VERY LOW	VERY LOW	VERY LOW	VERY LOW	MED	MED-HIGH	MED-HIGH	MED	LOW-MED	VERY LOW	VERY LOW
Hardness, MOH Scale (Rockwell RC)	5.5	7 (57-63)	6-7.5 (35-55)	6-7.5 (20-66)	8-9 (40-66)	8-9	9	8	5.5	3-4	1-4.5
Bulk Density (lb/cu. ft.)	100	150	280	280	230	125	95	130	100	45-60	40-80
Mesh Size	30-440	8-46	20-62	8-200	10-325	12-325	36-220	16-325	30-400	12-80	MANY
Typical Blast Pressures (psi)	20-55	20-90	20-90	20-90	20-90	20-90	20-90	30-80	20-50	20-60	10-40
Shapes: ▲ Angular; ● Spherical	●	●	●	●	▲	▲	▲	▲	▲	▲ or ●	▲

NOTES:

Above information is intended as a general reference guide. Consult your authorized Empire distributor for specific media specifications.

1) Sodium bicarbonate must be treated with a flow agent.

2) Do not use silica sand in a hand cabinet.

3) See "Media/Reclaimer Compatibility" chart on page 14 for mesh sizes that are compatible with reclaimer systems.

SILICA SAND IS NOT TO BE USED IN ANY EMPIRE BLAST EQUIPMENT.

WARRANTY: THREE YEAR LIMITED
 Consult Empire for details. For other literature or more information, consult your local Empire distributor, your Empire regional sales manager, or Empire company headquarters.
 Dimensions and specifications will vary with options and accessories purchased. SPECIFICATIONS ARE SUBJECT TO CHANGE WITHOUT NOTICE.

EMPIRE PRODUCTS

- A full range of cabinets—economy to custom
- Basket blasters for batch processing
- Automated blast systems
- Pneumatic blast & recovery systems
- FaStrip® plastic & wheat-starch decoating systems
- Blast rooms
- Outdoor portable systems
- Centrifugal-disc machines
- A full line of parts and accessories



2101 West Cabot Boulevard, Langhorne, PA 19047-1893
 Call: (215) 752-8800 E-Mail: Airblast@empire-airblast.com
 Fax: (215) 752-9373 Visit: www.empire-airblast.com